

Programmable controllers TMM[®] xxxx – 3 HELI for brushless sensorless motors (Version 2.52 and higher)

TMM[®] xxxx - 3 HELI controllers have been developed for helicopters and may be operated in one mode without constant revolutions and in one mode featuring constant revolutions (governor mode). They are manufactured with the use of surface mounting from high-end components and are controlled by a very powerful processor. Programming parameters are then saved permanently. The revolution regulation is extremely fine - 1024 steps all the way to the full throttle. The Mega BEC circuit (applies to versions with BEC) is also extremely powerful.

Thanks to the high-tech TMM[®] technology of MGM compo controllers feature number of outstanding properties which considerably eliminate the possibility of unwanted damage or destroy of motor, the batteries and the controller itself. Controllers also ensure the maximal efficiency with different kinds of motors.

Maximum attention is paid to development which is in continuous progress. To make our newest knowledge available to our customers the upgrade of SW is free (only shipping costs are charged).

The quality of products is under constant supervision in manufacture. Every controller goes through numerous tests. The final test of each controller is done under the controller's full load.

Protective and safety mechanisms of TMM[®] controllers:

Accumulators are protected in three ways. Firstly, due to the use of automatic current fuse (ACF) the current overload of accumulators (and their possible damage) even at crisis points can be avoided. Secondly, the used system of intelligent power reduce (IPR) always ensures through measurements of number of cells, voltage, currents, accumulator condition and calculations an optimal point of starting continuous reduction of motor performance (it is applied when accumulators become heavily discharged) so that accumulator cells do not get extremely discharged. This, not mentioning other advantages, reduces the possibility of reversal of poles of lower cells.

This system at the same time enables retaining defined energy for BEC (perfect RPC) in controllers that have BEC which is of great significance for flying models (a crash due to running out of energy for receiver and servos can be avoided) Thirdly, it is the automatic current reduce (ACR) due to which a drop in voltage for BEC under extremely big current load (for every given controller) while motor starts does not occur. **System also enables to indicate with programmed „time advance“, that batteries will be discharged soon This is very important for helicopters because at the begging of revolution reductions (almost discharged battery) there is usually not enough energy for flight.**

The controllers efficiently mask interference and drop-outs up to 1,5 sec. When long-lasting drop-outs or interference occur the controller slowly reduces motor revolutions. After the signal is resumed the controller continuously gets to the requested power. Without the proper signal from the transmitter (e.g. transmitter is turned off), the motor neither jerks nor runs but is at standstill.

Thermal fuse of the controller is set at 90°C – the controller only indicates this situation, it does not reduce power! After switching on, the temperature above 70°C is monitored; if the temperature is higher the controller does not start. New start is possible only after the controller temperature falls. Take notice that the controller warms up not only due to losses on switching transistor but also due to loss on BEC.

Intelligent power reduce (IPR) and retaining enough energy for BEC (RPC):

The controller's behavior at the point of exhausted batteries (or closely before that) is very significant from both the controlling point of view and economical use of remaining energy point of view.

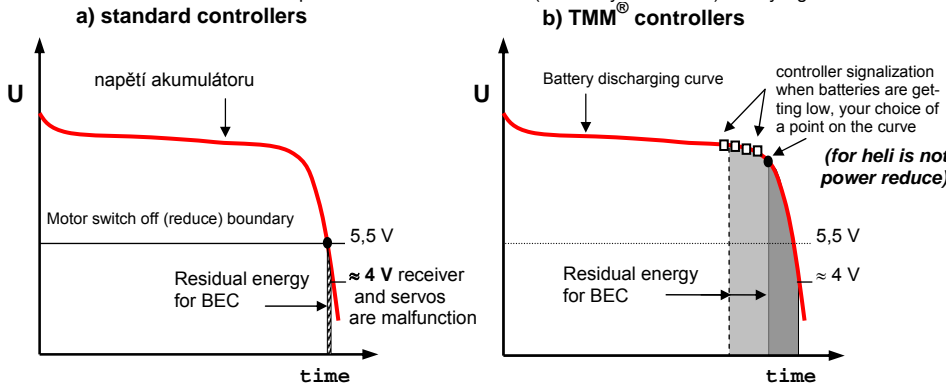

When switching (reducing power) the motor off at solid boundary (a) there is only very little energy remaining for BEC, particularly for 8 or more cells in battery pack. The better accumulators are used the less energy (time) is left to land (standard ESC).

Comparing to this, TMM[®] (b) ensures the remaining energy to be big enough; it is also possible to modify its size in some types (bigger for gliders). This energy is certainly insignificant as long as duration of running the motor is concerned, but it is very significant for feeding BEC.

In heli controllers, it is possible to set how long before the batteries are discharged you would like to be warned of this situation – motor revolutions are not reduced even on „rotor revolutions reduction boundary“

Operating data:

Temperature of the environment:	0°C to 40°C	Number of regulation steps:	1024 / full throttle
Motor controlling:	PWM 8 kHz	Max. rpm for 2 poles motor:	170 000 rpm
Control signal:	positive pulses 1,5 ± 0,5 ms, period 10 + 30 ms		
User set parameters:	see programming		
MEGA BEC:	5V / max. 4,0 A (power losses 5W continuous, 10W / 10 sec., 15W / 5 sec., max. 20W, see graph)		
Power supply:	from batteries only: NiCd, NiMH, Li-Ion, Li-Pol		
Suitable for motors:	Mega AC, Model Motors, MP JET, PJS, Überall model, Hacker, Kontronik, LRK, Plettenberg, etc.		
	for 2 to 20 pole motors of classical conception (rotor inside) and also for outrunners (rotor is on the outer side).		

TMM [®] xxxx-3 HELI:	1210-3	2512-3	4412-3
Dimensions [mm]:	25×23×6	28×25×6	36×28×6
Dimensions (with external capacitor) [mm]:	25×23×6	44×25×6	51×28×6
Weight incl. all conductors:	9 g	19 g	32 g
Weight without power conductors:	6 g	10 g	18 g
No. of feeding NiCd/NiMH cells:	6 – 10	6 – 12	6 – 12
No. of feeding Li-Ion / Li-Pol cells:	2 – 3	2 – 4	2 – 4
Max. current (for full throttle):	12 A	25 A	44 A
Max. current for 5 sec.:	15 A	30 A	55 A
On-state switch resistance at 25 °C:	2×6,3 mΩ	2×3,1 mΩ	2×1,2 mΩ
Model:	MEGA BEC	MEGA BEC	MEGA BEC
BEC voltage:	5 V	5 V	5 V
Power conductors length/cross-section:	7 cm/0,5 mm ²	1,5 mm ²	2,5 mm ²
JR gold connector, cables:	0,15 mm ²	0,25 mm ²	0,25 mm ²
Possibility of Indication:	LED	LED + buzzer	LED + buzzer

Cooling: for the best cooling of the controllers with two and more plates is possible add (from both sides) external heatsinks 50×31×5mm or 38×31×5 mm. Thickness increase about 5.6 mm only, weight increase about 6 grams [short], or 10 grams [long heatsinks].



TMM [®] xxxx-3 HELI:	6012-3	8012-3	6016-3	8016-3	4024-3	8024-3	6032-3
Dimensions [mm]:	50×31×14	50×31×14	50×31×14	50×31×14	50×31×10	50×31×13	50×31×13
Dimensions (with external capacitor) [mm]:	62×31×14	62×31×14	65×31×14	65×31×14	80×31×10	80×31×13	80×31×13
Weight incl. all conductors:	55 g	57 g	55 g	57 g	53 g	60 g	60 g
Weight without power conductors:	40 g	42 g	40 g	42 g	38 g	45 g	45 g
No. of feeding NiCd/NiMH cells:	6 – 12	6 – 12	7 – 16	7 – 16	7 – 24	7 – 24	7 – 32
No. of feeding Li-Ion / Li-Pol cells:	2 – 4	2 – 4	3 – 5	3 – 5	3 – 8	3 – 8	3 – 10
Max. current (for full throttle):	60 A	80 A	60 A	80 A	40 A	80 A	60 A
Max. current for 5 sec.:	70 A	100 A	70 A	100 A	50 A	100 A	70 A
On-state switch resistance at 25 °C:	2×1,0 mΩ	2×0,67 mΩ	2×1,0 mΩ	2×0,67 mΩ	2×1,4 mΩ	2×0,7 mΩ	2×1,5 mΩ
Model:	MEGA BEC	MEGA BEC	OPTO	OPTO	OPTO	OPTO	OPTO
BEC voltage:	5V	5V	--	--	--	--	--
Power conductors cross-section:	2,5 mm ²	2,5 mm ²	2,5 mm ²	2,5 mm ²	2,5 mm ²	2,5 mm ²	2,5 mm ²
JR gold connector, cables:	0,25 mm ²	0,25 mm ²	0,15 mm ²	0,15 mm ²	0,15 mm ²	0,15 mm ²	0,15 mm ²
Possibility of Indication:	LED + buzzer	LED + buzzer	LED + buzzer	LED + buzzer	LED + buzzer	LED + buzzer	LED + buzzer

The appearance and operating data may be changed without prior notice.

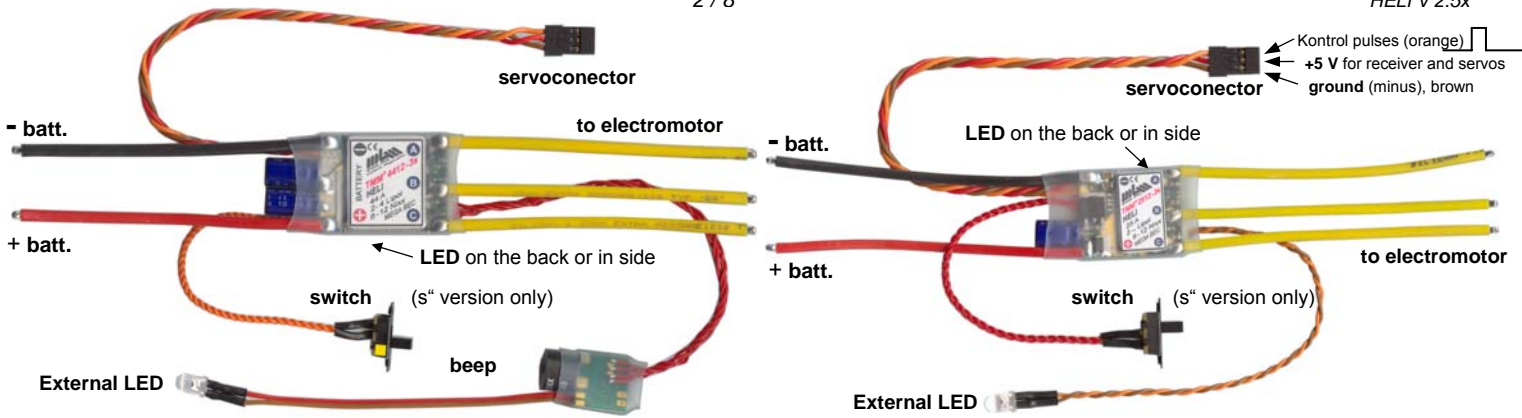

State indication: a) by external super bright LED (standard equipment)
 b) by external super bright LED and Buzzer (option)

Note:
(for BEC versions only !!!)
 If you need to feed the receiver or servos from some other source carefully take out the central core of the servo cable connector. The taken out core of this conductor must be properly insulated.!

MEGA BEC: controllers up to 12 cells are equipped with BEC. The BEC can hold peak currents up to 4A and loss power loads which are significantly big but has its limits. It may not exceed 20W. It is possible to determine for example current which may be drawn from BEC under given load and voltage and also find out for how long from the graph. **The power losses of the BEC warm the controller up. It is necessary to remove the generated heat by airflow.** If the BEC is loaded with the power loss >5W pauses for cooling are necessary so that the average power loss is ≤ 5W.

Power loss of BEC: $(U_{batt} - 5V) \times current\ I$

Example: (see graph) if voltage of batteries is 10,5V it is possible to draw current of 1,8A continuously for 10 sec. when the power loss of BEC is 10W. If the load would only take 5 sec. the power loss may be 15W and it is possible to draw current up to 2,7A.

When exceeding the maximal limits of current or power losses, BEC may be destroyed and the model may be uncontrollable !

BEC have not fuse for overload or short circuit !

Please, notice that servos loaded with the control surfaces (rudder, ailerons etc.) in the air draw many times more current than when you move them on the ground !

Many micro servos and digital servos consumption more current then standard servos.

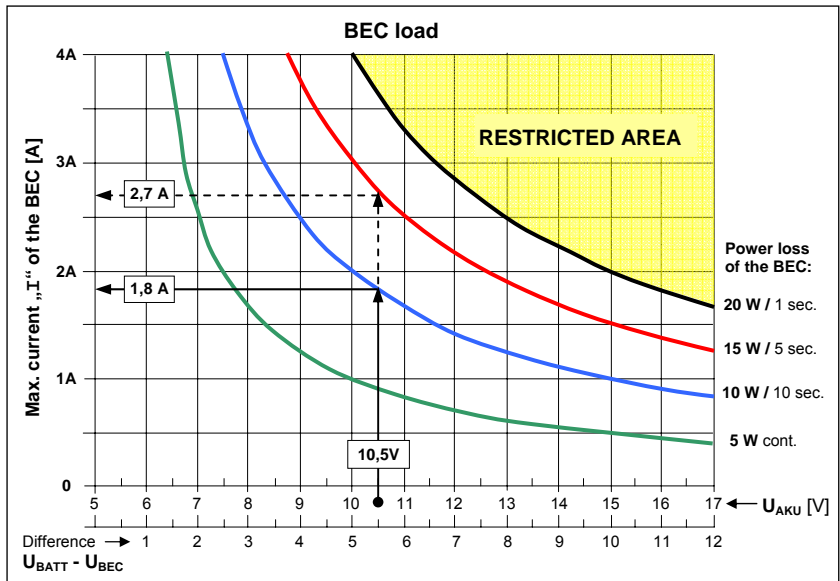

Instructions for use:

- Opposite piece of the connector, which is on your accumulators, should be soldered to the leading-in conductors to the accumulator. Use only quality golden plated kinds. We recommend the MP JET 1.8mm, 2.5mm or 3.5mm depending on the type of controller and current; or Schulze 3,5mm connectors (they are not interchangeable); or golden plated connectors Ø 4 or 2mm. The MP JET connectors have considerable smaller contact resistance. We recommend to put socket on the “-” wire (black wire) of the controller and the plug on the “+” wire (red wire).
- Use power conductors as short as possible – it is better for minimum weight and for minimum interference. Receiver and antenna should be placed as far as possible from the controller, the batteries and power leads.
- **NOTICE, reversal of poles on wires to the batteries will destroy the controller !**



- The leads to the motor (yellow wires marked “A”, “B”, “C”) should be soldered directly to the motor or it is also possible to use the connectors mentioned above. If you decide to use connectors, this time solder sockets to the controller leads ! **Short cut of these wires together (when batteries are connected) or short cut of these wires to the feeding voltage results in damage or destroy of the controller !**
- After the connectors are soldered it is necessary to isolate them, for example with heat shrinking sleeve ! (the connectors on pictures are without isolation sleeve for better clearness)
- If you need the motor to run in an opposite direction, swap any two motor phases.
- **It is necessary to cool the controller in operation with flowing air. Do not prevent the cooling air to get to the controller (e.g. by packing it in foam).**
- The controller informs of overload and overheating acoustically (motor beeping) and also through LED.
- The switch of the controller is connected in such way that even if it gets damaged the BEC will be still functioning.
- **The controller is switched on by TURNING OFF the switch** (applies to “s” version with switch) or by connecting batteries (applies to versions without switch).
- **Do not switch off or disconnect the controller from batteries when motor runs or when it is still turning – that may lead to damage or destroyed of controller !!!**
- **Current fuse in “heli” controllers is not active ! Current in some flying phase can be significantly higher then current measuring on the ground ! It is better have your controller over equipped.**
- **Feed your controller only from the battery - feeding from power supplies can destroyed your controller !!!**



Development, manufacture, service:
 MGM compro, Ing. G. Dvorský,
 Sv. Čecha 593, 760 01 Zlín, Czech Republic

Tel.: +420 577 001 350, fax: +420 577 001 348
 E-mail: mgm@mgm-compro.cz
 Info: www.mgm-compro.com

Controller may be operated in 2 different modes.

1) HELI 1 (NOT equipped with constant revolutions feature)

In this mode, the controller does not hold constant revolutions of the motor – instead, it behaves like aircraft controllers with the exception of fuses and signalization, which are set differently to better suit helicopters' needs. Motor together with controller behaves similarly to glue engine, also setting of transmitter is the same, which means that mix PITCH – THROTTLE (GAS) and their curves are set the same way as if flying with glue engine. Throttle (gas) channel must be assigned to controller (e.g. CH1 for mc-16/20, CH6 for mc-22, CH3 for FC-18, FC-22 etc.). Throttle curve must be set so that changes in revolutions with change of load would be as small as possible. However, changes in revolutions (decrease) when drop in voltage occurs cannot be compensated in the manner described above.

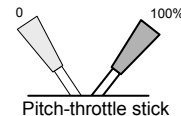

2) HELI 2 (features constant revolutions, manual setting)

Controller must be assigned to any available (unoccupied) channel (e.g. CH5 for mc-16/20, FC-18), **which is not mixed with pitch.** "Throttle" value control potentiometer, of that channel is used to easily set constant revolutions that you desire in the range 50 up to 100% of programmed maximum (according to the sound, or revolutions meter). Constant revolutions are indicated by external LED (continuous light). If you need to change revolutions, just set new desired revolutions using the volume control and the stabilization process will be repeated. It is quite similar to a cruise control in car.

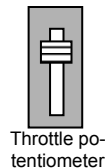

Before setting this mode, it is necessary to first "adapt" the controller to your set (transmitter, motor, batteries) – and set maxima rotor revolution, according to the "Revolutions programming", see next section. To obtain smoother revolution setting, revolutions in the range of 50 to 100% of max are "spread" through the whole throttle range (outside the area of autorotation).

A great advantage of modes with constant revolutions is that revolutions of the motor (or Rotor) are held while change of load significantly better than it is possible to do so with throttle and pitch curves on transmitter, and constant revolutions are also held even when drop in voltage occurs

Current fuse is disabled in heli controllers. Thermal fuse only indicates overheating – motor revolutions are not reduced, nor switched off – it is necessary to land immediately. Circuits that watch the voltage of batteries also only activate indication of batteries getting discharged soon, motor revolutions are not reduced, nor is the motor switched off - it is necessary to land immediately.

INDICATION of working states:

- after switching the controller on, 1x (beep+LED), after throttling to zero you may take off
- in constant revolutions mode external LED is on – if blinking, it indicates that there is not enough energy left
- controller is in autorotation mode (-85% up to -95% throttle position), continuous beeping by external buzzer
- Controller is overheated – **land immediately !!!**
- Voltage of batteries are close to reduction boundary – the situation is indicated with the programmed time advance – **land immediately !!!**

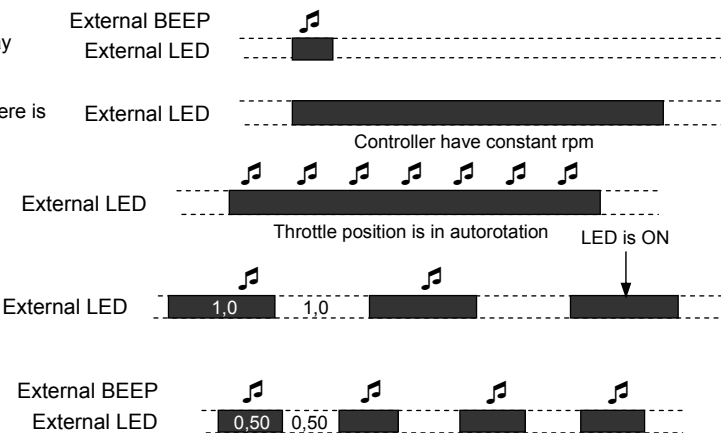

Note: when is buzzer no connection, indication is by external LED only.

Error messages (♣ - the controller must be switched off to correct error, then switched on again):

- throttle stick was moved the opposite way then it is supposed to (the thrtolle stick was not in the min or max position at the beginning, and after beep it was moved to the max or min position to which the throttle was closer and not the other (correct way) ♣
- low size of deflection of the throttle stick on the transmitter – you must shorten the size of deflection on transmitter ♣
- overstep max. throttle position 0,5 and 2,5 ms – you must shorten the size of deflection ♣ ...
- switching on the controller with turned off transmitter ♣
- switching on the overheating controller ♣
- more or less cells than specified ♣
- signal drop out for long time
- sustained beep after switch on – data corruption in EEPROM. Controller is setup to factory parameter. You must programming your setup again !
- defective EEPROM – send to servis !
- defective HW – send to servis !

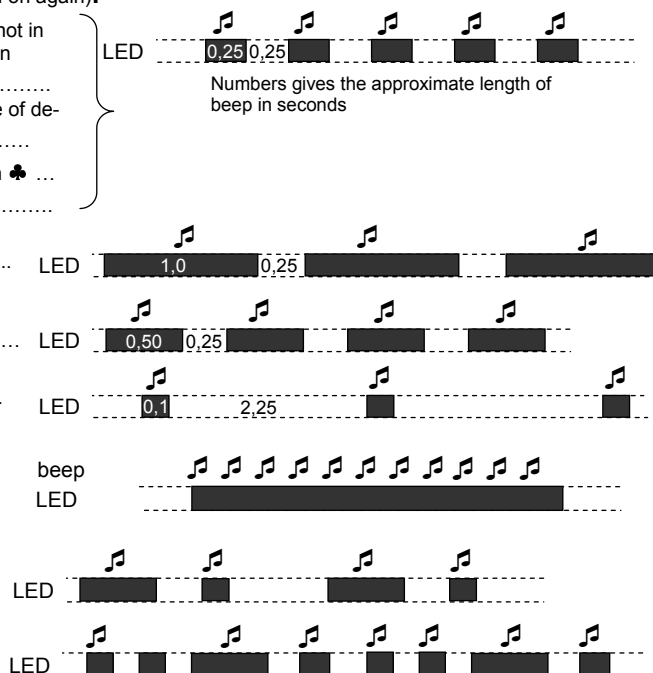

It is necessary to program the controller before its first use!

Controller is set in mode **HELI1** from manufacture with default setting of parameter, see table **bold and underlined**. (see below)

Nevertheless, even in this mode it is necessary to at least program max and min positions of throttle stick. That means, only set the programming mode (see further below for section „CONTROLLER PROGRAMMING“) and then turn the controller off, it is not needed to set any other parameters if you do not wish to.

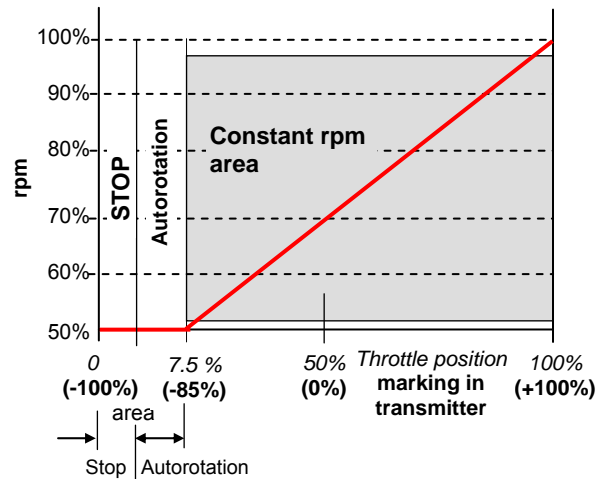
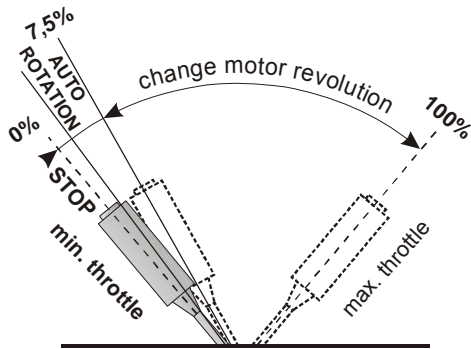

It is recommended to program while landed (with rotor blades in 0° or minus degrees angle)

PROGRAMMING:

All programming is done through transmitter and receiver with which the controller will run. After programming the data will be saved (until possible next programming) and the controller must be switched off. After switching it on again it is ready to fly. If after switching on, the throttle stick is not in the min position the controller waits for it to get there –100% (safety precaution – you will be warned by beeping) – if the throttle is in its min position you may take off immediately.

Description of parameters in the programming mode:

Parameter A – mode choice: enables to choose mode (*HELI1, HELI2, Revolutions setting*)

Parameter B – deceleration: enables to set speed of motor revolutions reduction -7 different values or to set freewheel

Parameter C – acceleration: enables to set acceleration (acceleration speed of motor in normal operation) - 5 values. The slow acceleration after start (rotor is stopped) is deduced from the set value.

Parameter D – timing: here you may choose (and experiment with) 5 different timings. The sixth possibility is automatic timing which is strongly recommended because it ensures optimal setting and maximal efficiency. While using the definite values of timing and higher timing you may rise the motor revolution or the twisting moment a bit but always at the expense of lowering the efficiency. If you wish to have higher revolutions it is better to use different motor or more cells because lower efficiency cannot be made up for. High value of timing may in unsuitable combination with some motors damage the controller!
Motor with high inductance (for example AXI 4120): setup timing 5° or 10°, automatic timing may not be optimal.

Parameter E: **controller signalization when batteries are getting low:** this parameter sets how long before the accu are discharged you will be warned of this situation by controller signalization. Try and set the best time that would suit you and you set

Parameter F – battery: choice of the battery type, Nicd, NiMH or Li-Ion, Li-Pol

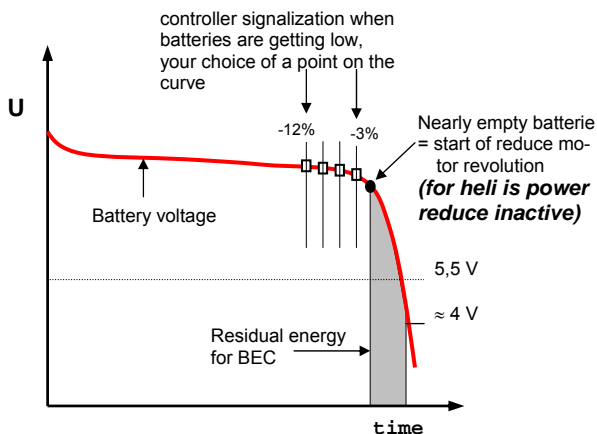

WARNING :

You risk destroying the controller for:

- connecting more battery cells to the controller than the max. number specified in the technical data
- reversing connections to the accumulator
- shortcutting of wires to motor when batteries are connected
- changing motor and accumulator outlets
- overloading of the BEC with bigger currents or bigger power loss than is specified in technical data
- water in the controller (except for „hydro“ versions“)
- metal objects in the controller (screwdrivers, wires, etc.)
- disconnecting the controller from batteries or turning off the controller while motor is running (or still turning)

PROGRAMMING OF THE CONTROLLER:**How to program the desired “value” in parameter you are setting** (basic procedure in each parameter):

Move the throttle stick (*) to ½ throttle, internal LED will be switched off 2x (twice) and motor beeps 2x. Move throttle back to min position, internal LED will be switched off once and motor beeps once. Repeat this procedure (½ throttle – min throttle) as many times as is the number of parameter (according to the table) you wish to set. **For example:** for setting the **number 3** in parameter D (that is timing 10°) repeat the whole procedure (1/2 throttle – min throttle) **3x** (you certainly have to be in parameter D first).

The programming of each parameter will be finished when you move the throttle from min position to the full throttle – internal LED will be turned off 3x and motor will beep 3x, then move the throttle back to min position, internal LED will be turned off 1x and motor will beep once – the parameter is programmed to the value you have chosen and saved (**this sequence is marked as “ENTER”**). This also automatically gets you to next parameter. After the last programmed parameter the controller must be always switched off first ! It is not obligatory to program all parameters, therefore after any parameter correctly saved with “ENTER” procedure the controller may be switched off. The following parameters will not be changed and all preceding parameters will be saved.

If you do not wish to change some parameter (you wish to preserve its last value) directly set full throttle when programming it (no ½ throttle – minimum procedure, but directly ENTER). The parameter value stays as it was before and the controller will get to the next parameter programming.

***) Note: Here, by “the throttle stick” is meant:**

- throttle assigned to pitch stick in regular flight operation (when pitch- throttle stick truly controls also throttle in the whole range –100% up to +100%, AR switch, flight mode switch (0-1-2), and also 3rd throttle are switched off) or
- throttle on separate channel (mode HELI 2)

I) Turn the transmitter on with throttle stick in max position !

II) Turn on the controller. After 10seconds the controller will beep 3 x and LED will blink and stay turned on. Now you have 3 seconds to move the throttle back to zero. If in this time limit you do not put the throttle in min position the programming process will end and the controller will be turned off. **Its next operation is possible after switching it off and then turning on by switch (disconnecting and connecting of batteries).** If you put the throttle to zero in this time limit the motor will beep 1x and the green LED will be turned off 1x. Now you are in the programming mode and may start to program parameters according to the procedure described above.

III) Parameter A – mode choice:**1) reserve****2) Mode HELI 1:**

Move the throttle to ½ throttle position, internal LED will be turned off 2x and the motor will be beep 2x. Move throttle back to min position, internal LED turned of 1x and motor will beep 1x. Repeat this procedure once more (you were setting **value 2** of this parameter) This choice will be confirmed by moving the throttle from min to full position – internal LED will be turned off 3x and motor will beep 3x. Then move back to min position and LED will be turned off 1x and motor will beep 1x. The default setting is set and timing of your set (transmitter – receiver) is saved. Now, you have chosen mode Heli1 and proceed to programming of parameter B

3) mode HELI 2, constant revolutions, manual setting using potentiometer:

Set **value 3** of this parameter. Now you have chosen mode Heli2 and will proceed to programming of parameter B..

4) reserve**5) Revolutions setting:**

Set **value 5** of this parameter. **Now you will proceed directly to setting the requested maximal revolutions.**

IV) parameter B – deceleration:

set according to the “How to program the desired “value” in parameter you are setting” (see above) set the desired value and move to next parameter.

V) parameter C – acceleration:

set according to the “How to program the desired “value” in parameter you are setting” (see above) set the desired value and move to next parameter

VI) parameter D - timing:

set according to the “How to program the desired “value” in parameter you are setting” (see above) set the desired value and move to next parameter

VII) parameter E - controller signalization when batteries are getting low:

set according to the “How to program the desired “value” in parameter you are setting” (see above) set the desired value and move to next parameter

VIII) parameter F – type of batteries:

set according to the “How to program the desired “value” in parameter you are setting” (see above) set the desired value. By sequence „ENTER“ (set full throttle – back to min. throttle) you terminate programming.

IX) Turn off controller !

Notice: **If you do not wish to change some parameter during programming,** move directly to full throttle when programming it (no ½ throttle –minimum procedure). This will keep the last value and get you to programming of next parameter (**applies to all parameters except for the first one (A) which has to be set !!!**)

Parameter	Value of parameter →	0 (set ENTER directly)	1	2	3	4	5	6	7	8		
A	Mode choice	next parameter	Reserve, no use	HELI 1	HELI 2 (governor mode) const. revolution.	Reserve, no use	<i>Revolutions programming</i>	–	–	–	–	v
B	Deceleration	next parameter	freewheel	0,6 s	1,0 s	1,6 s	2,1 s	2,6 s	3,1 s	3,9 s	–	–
C	Acceleration	next parameter	0,4 s	0,6 s	1,0 s	1,6 s	2,1 s	2,6 s	3,1 s	3,9 s	–	–
D	Timing	next parameter	automatic	5°	10°	15°	20°	25°	–	–	–	–
E	Signalization	next parameter	Nixx: 0,80 V Lixxx: 3,10 V	0,84 V 3,14 V	0,88 V 3,18 V	0,92 V 3,22 V	0,96 V 3,26 V	1,00 V 3,30 V	1,04 V 3,34 V	1,08 V 3,38 V	–	–
F	Battery type *)	End of programming.	NiCd, NiMH	Li-Ion, Li-Pol 2 cells	Li-Ion, Li-Pol 3 cells	Li-Ion, Li-Pol 4 cells	Li-Ion, Li-Pol 5 cells	Li-xxx 6 cells	Li-xxx 7 cells	Li-xxx 8 cells	Li-xxx 9 cells	Li-xxx 10 cls.

Notice: - Default setting is marked **bold** in the table

*) maximal number of Lipol cells for a controller is given in technical specifications for each controller (**page 1**)

REVOLUTIONS PROGRAMMING – maximal revolution setup (for HELI 2 mode):

Make sure that controller is assigned to a separate channel that is not mixed with anything else! Then **Go through programming steps I, II and III – 5** (see previous page), that will get you to „revolutions programming section“ - **external LED will blink 3 times.**

If you now move the throttle above the autorotation region, the controller will start to turn the motor slowly. Set requested revolution value by throttle moving up – it is recommend measure rotor rpm by revolution counter. When is set requested rpm, move throttle to minimal position.

When the rotors are at standstill, turn the controller off, the programming is finished. (If necessary, you may stop the motor anytime during this procedure by dropping the throttle to zero – however, the “revolutions programming” will be aborted.)

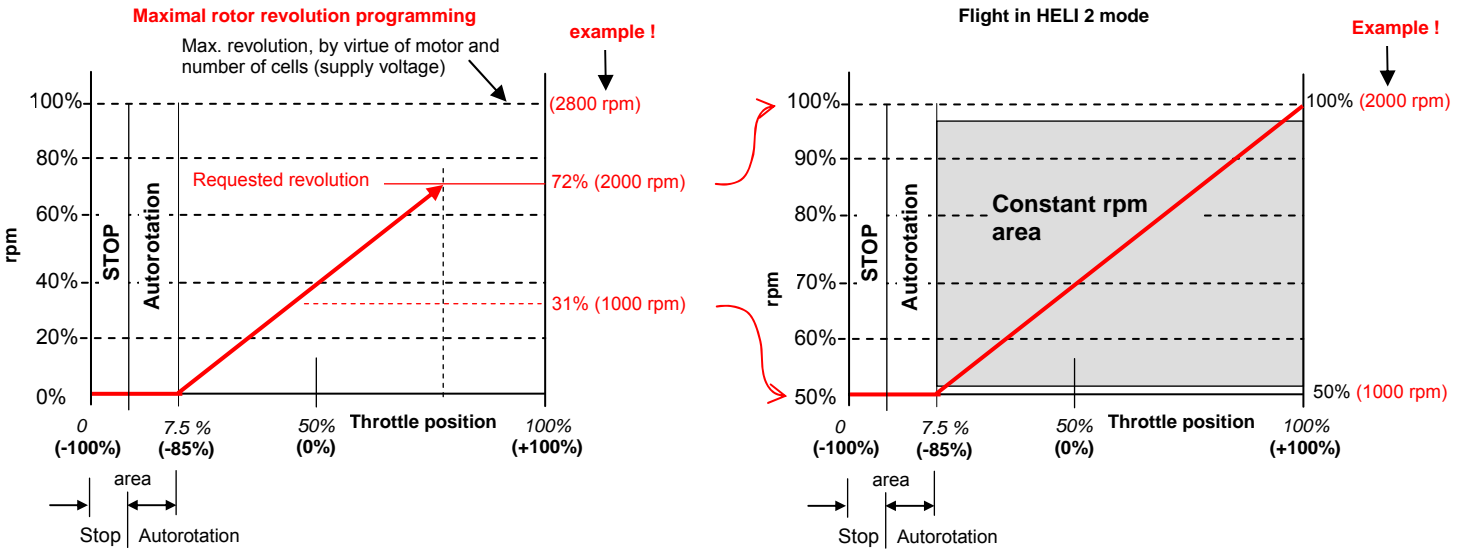

After switching the controller on again, it is possible to now fly in the Heli 2 mode. Remember, that right above the autorotation area there is a 50% of max revolutions – revolutions rise slowly to that range.

The “revolution programming” must be done always when there is a change in motor, gear ratio, number of cells, set and always with a new controller.

It is enough to program the HELI 2 mode just once, it is not necessary to program it after each programming of revolutions. Please do not mix up the “Revolutions programming” with the change of revolutions by the throttle stick.

Autorotation switch setup:

If you wish to fully use all advantages of controller even in autorotation (fast acceleration) in modes HELI1, HELI2 it is necessary to assign this switch on transmitter a correct deflection to cooperate with controller. In controller the autorotation area is defined between -95% and -85% of the whole throttle deflection (-100% up to +100%) it is necessary to assign the „ON“ position on the autorotation switch on transmitter this value in this range (-95% up to -85%). It is recommended to check, if necessary also to trim this value by setting the transmitter. If the setting is in this range (correct for controller) controller will continuously beep. It is best to set the value on transmitter to the middle of the autorotation area in which the controller beeps. Remember to also save this setting in your transmitter. Please note that if you set too high value (>-85%) the motor will start to turn slowly (to 50% of maximum).

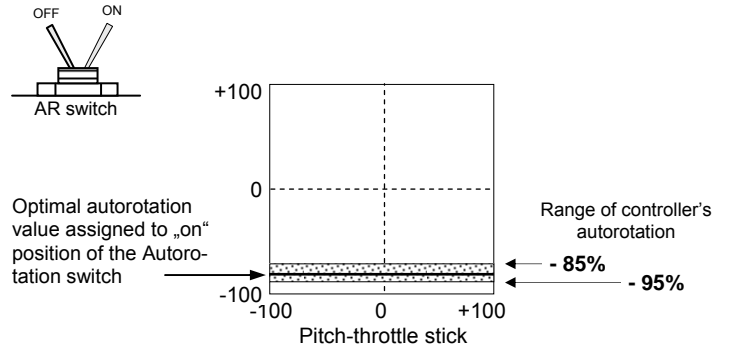

The Start up of motor from position 0 (rotor is not turning) is slow so that mechanical parts of helicopter are not exceedingly stressed by big inertial mass. On the other hand, start up from autorotation position is fast – when practicing autorotation there is no time for slow start up, moreover the rotor is already turning.

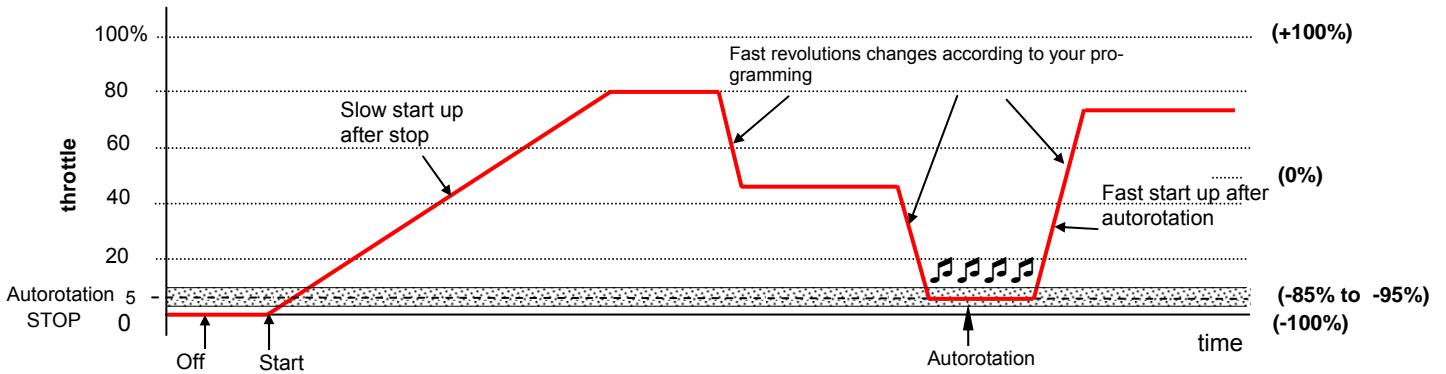

SECURITY WARNING:

Always disconnect the accumulators when not operating the model !!! Small current consumption occurs even when controller is switched off. Do not leave model with connected accumulators unattended ! Do not charge batteries when connected to the controller ! If the controller is connected to batteries do not stay in the reach of the propeller even when the controller is switched off ! Please notice that running motor with propeller is very dangerous !

PROGRAMMING TMM xxxx – 3 HELI

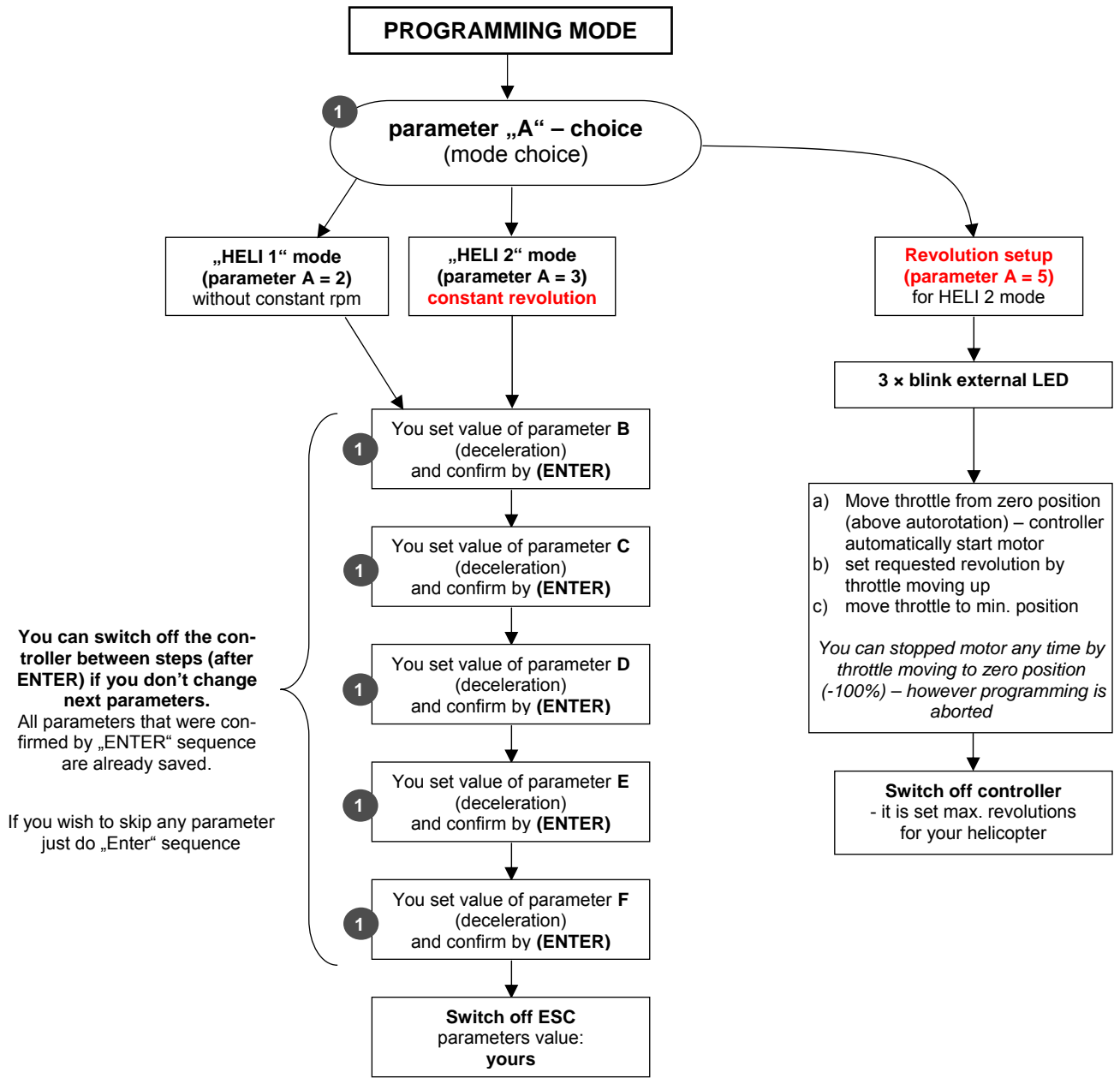

Legend:

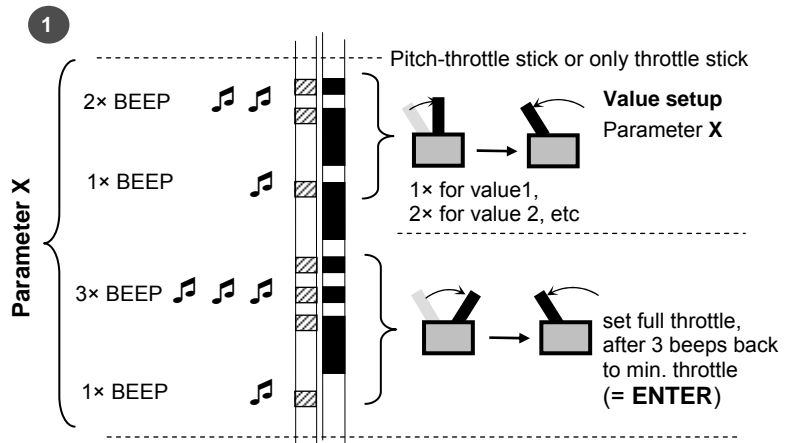
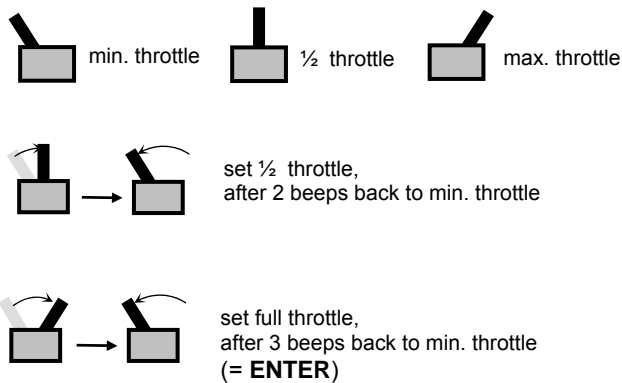

PROGRAMMING TMM xxxx – 3, HELI

User parameters setup

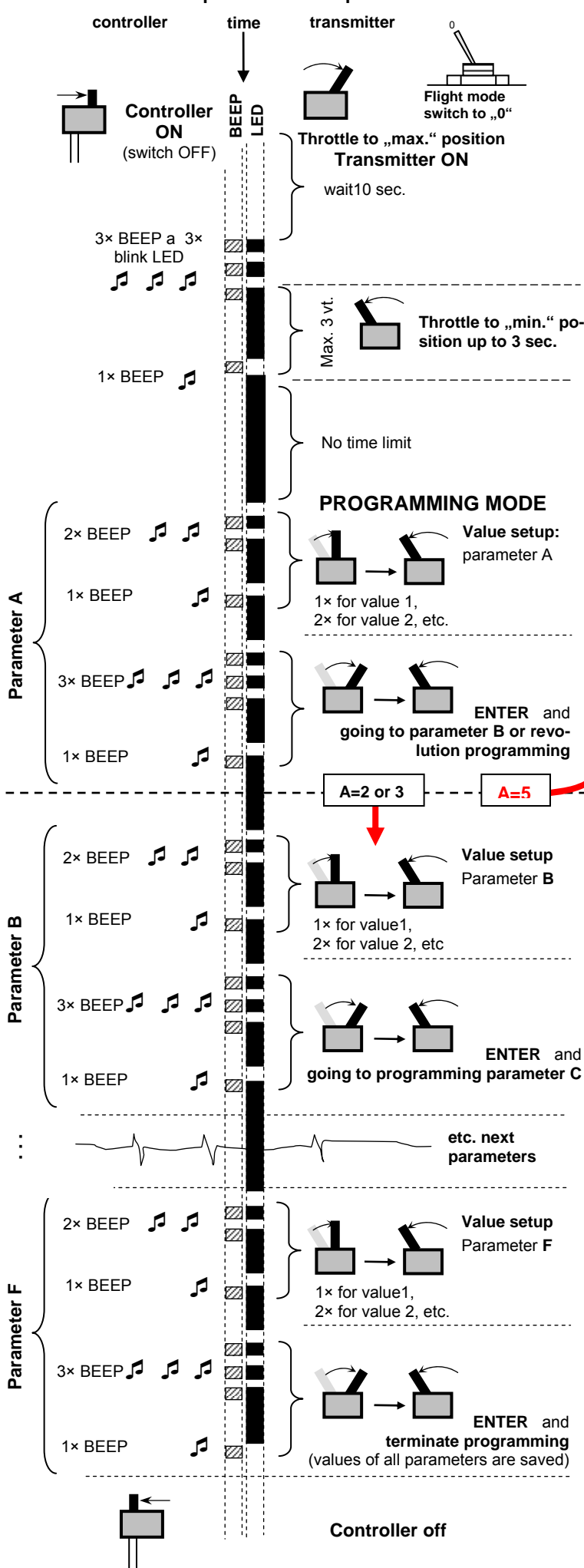

Revolution programming (parameter A = 5)

