

Processor controlled Balancers BLCR 4 are designed for reliable and easy balancing of Lipol/ Li-ion cells in battery packs.

Balancers may be used with chargers based on both – direct current and also pulse charging currents. They are processor controlled and are calibrated in manufacture therefore need no additional setting us any trimmers, etc. The cells are balanced shortly after connecting the balancer to the cells. An advantage of this approach compared to balancing cells on end voltage of 4.2 V/cell is that cells can be balanced even if the charging is finished early (e.g. cells are charged to 70% and you need to start flying immediately). Another benefit is the possibility to charge the cells with currents much higher than what the balancer can balance. Thanks to a processor balancers identify defective, damaged or under discharged cells and inform of this situation acoustically and by LED. If voltage of all connected cells exceeds 4.25V/cell (*defective or incorrectly set charger*) balancer will not allow another increase of voltage and informs of this acoustically and by LED. Also informs if voltage of any cell rises above 4.25V/cell (*charging current too high compared to balancing currents, very unbalanced cells*).

How to begin (easy and quick):

Battery pack that is wished to be balanced must be equipped with a service connector „SCA_3“ to „SCA_5“, (battery pack with a service connector can be either ordered already soldered to battery pack or you can solder it to battery pack yourself). Connect the battery pack to the charger and set the required charging mode (*according to the possibilities of the charger*) and start charging. Now, place the battery pack using the service cable with connector „SCA_x“ into balancer. Immediately after battery is connected balancer testing and blinking by all the LEDs. Immediately after that, the balancer will recognize the number of connected cells (for check) and by switching on green LED 1 to LED 4 shows connected cells with voltage in allowed limits. Cells with voltage out of the limits are marked by blinking LED. If voltage of any of the cells is less than 2V, LED of this cell stays switched off. After 5 seconds all LEDs are switched off, start blinking and the balancing process starts. If the overall voltage of cells is <6V, (till voltage of 3.5V) balancer waits until the overall voltage gets over 6V – until then only warns by beeps and blinks.

If the charging current is not higher than the balancing current of the balancer the battery pack is balanced very fast and even if charging is finished before the pack is fully charged the battery pack will be balanced.

Example of battery pack with power leads, connectors MP JET 2.5 and service connector SCA_4:

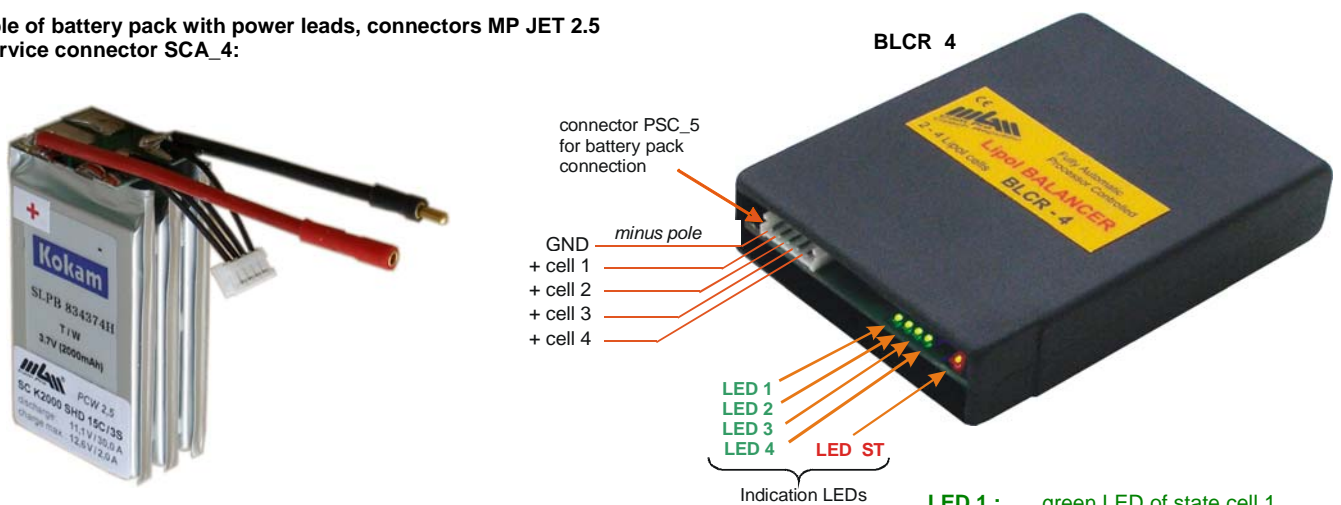

- LED 1 : green LED of state cell 1
- LED 2 : green LED of state cell 2
- LED 3 : green LED of state cell 3
- LED 4 : green LED of state cell 4
- LED ST : red LED of error indication

How to connect balancer to the battery pack and charger:

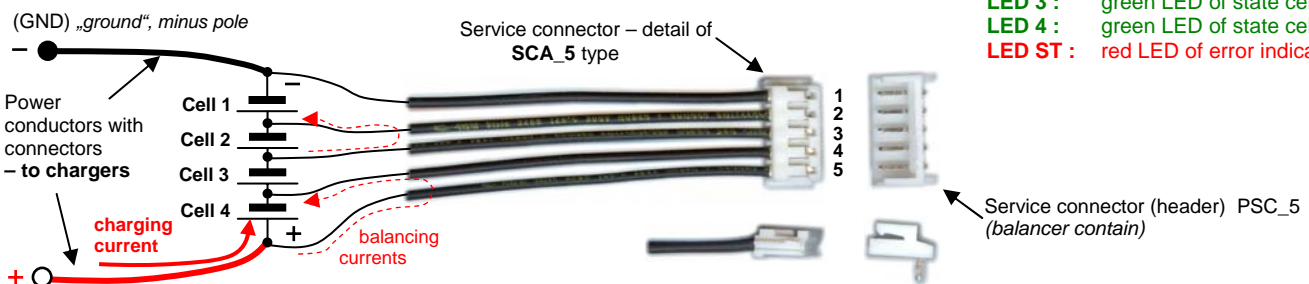

Technical parameters of Balancers:

| | |
|----------------------------------|---|
| Temperature of environment: | 0°C up to 40°C |
| Type of allowed chargers: | direct current / pulse charging currents |
| Serial connection of balancers: | no |
| Indication of balancing process: | intensity of the LED light |
| Indication of state and errors: | LED and/or BEEP |
| Error states: | - cell voltage < 2V - cell voltage in the range 2V up to 2,95V - some of the cell voltage > 4,25V - all cell voltage > 4,25V |
| Emergency states: | - disconnection cell, all cell voltage < 6V |

| BLCR 4 | |
|--|---------------|
| Dimensions [mm]: | 90x68x18 |
| Weight: | 50 g |
| Number of balancing Li-Ion / Li-Pol cells: | 2 – 4 |
| Max. balancing current (short time): | 0,65 A (1,2A) |
| Max. charging current (it depend on the cells also): | up to ~2,6 A |
| Balancing accuracy (typically): | ± 10 mV |

The appearance and operating data may be changed without prior notice

Outstanding features of balancers BLCR 4:

- a) compared to balancers that as a matter of fact do not balance the voltage of cells only limit the voltage on maximal values (e.g. 4.25V), these balancers do in fact actively balance the voltage of cells during the whole charging process.
- b) no settings needed, high accuracy is ensured by calibration during manufacture
- c) cells are balanced with accuracy in mV (typically less than 10mV)
- d) recognizes defective, damaged and undercharged cells thanks to a processor, informs of error and emergency states
- e) cells are balanced shortly after start of balancing process (even not fully charged cells may be balanced)
- f) may be used with all type of Lipol chargers (direct current or pulsed current)
- g) high balancing currents
- h) charging currents may be several times higher than balancing currents
- i) reverse polarity protection
- j) small dimensions and light weight
- k) non-interchangeable industrial connectors PSC_5 (for connecting to service connectors SCA_3 to SCA_5 used for battery packs)

Indication after switch on:

- immediately after switch on, testing starts and all LEDs flash.
- short time after switch on (connecting the cells to balancer) the connected cells are indicated for ca 5 sec. by lit up corresponding green LEDs and also as many beeps as the number of connected cells will be heard.
- if in this time green LED of any cell is not lit up, the voltage of the cell is < 2V, the cell is missing or the wire / service connector is damaged !!! (*must be repaired !*)

After 5 sec. LEDs are turned off and balancing process starts. Intensity of brightness of particular green LED indicates its difference from the most charged cell. If the cells have similar voltages, LEDs are lit up with the smallest intensity. **These LEDs blinking in ca 1 sec. intervals for 0.25 sec. period - this indicates that everything is alright:**

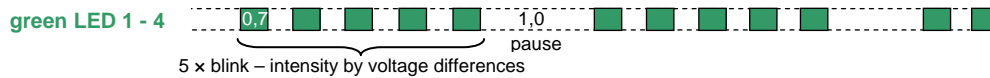

In consequence of the testing and possible communication can shortly blinking also other LEDs, not only LEDs corresponding with the connected cells. The intensity of light of red LED ST indicates the reduction of the balancing current in case high temperature of device. These LED switches off in intervals of 1 second for 0.25 second also. Lighting of this LED without acoustical beeps is information only, it is no warning.

Error indication:

- the voltage of the corresponding cell 1 to 4 is between 2,0 to 2,95V !!! (cell is under discharged)



Emergency Warnings !!! (User interference necessary):

- voltage of some the cells exceeded 4.25V/cell (balancing currents are too high / cells are too different or defective - necessary to lower the charging current ! - balancer cannot balancing so higher current)
- voltage of all the cells exceeded 4.25V/cell (balancing currents are too high - necessary to lower the charging current !) (defective charger or incorrect settings of charger - necessary to switch of and make corrections !)
- the overall voltage of connected cell is < 6V (cell / cells significantly undercharged - wait for the voltage to rise - watch closely !)

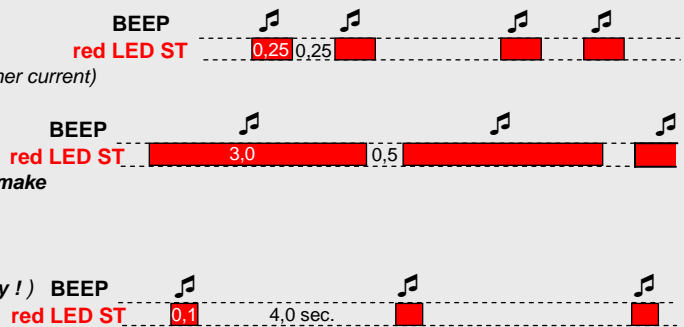

Example of charging set: charging of „SC K2000 / 3s“ cells with service connector with charger „AQC 4F“ + balancer „BLCR 4“ (charging current 3.96A, 2C, cells are not too different, small voltage different between cells, balancing current needed is low - LED of the second cell is light only a little)



SECURITY WARNING:
 Do not connect to battery pack unless the charger is turned on !!! Balancer draws a small current of 20 to 30mA from the battery !!!
 Do not leave without attention !!!
 Do not leave on direct sunlight !!! Protect from water !!!



Development, manufacture, service:
 MGM compro, Ing. G. Dvorský,
 Sv. Čecha 593, 760 01 Zlín, Czech Republic

Tel.: +420 577 001 350, fax: +420 577 001 348
 E-mail: mgm@mgm-compro.cz
 Info: www.mgm-compro.com