

Balancing charger for Lipol / Li-Ion cells AQCB – 4FC

(Version 3.22 and more)

Processor controlled chargers with embedded balancer AQCB – 4FC are designed for safe, quick and easy charging and at the same time balancing of Lipol and Li-Ion cells, include Li-Ion cells "A123 system" (charging voltage 3.6V).

Even though very small in dimensions, AQCB – 4FC with all its features and power is an outstanding high-tech MGM compro[®] charger for charging 1 to 4 Lipol / Li-Ion / A123 systems cells. Charging current may be as high as 5A. Current is set manually using switches. Number of cells is automatically detected with the service connector. Balancing process starts shortly after the charger is turned on. Crucial advantage of such balancer conception (compared to voltage limiters) is that cells are actively balanced and are not unbalanced after charging which may easily happen with voltage limiters (often also called balancers). The possibility of balancing cells even when charging finished early is advantageous (charged to e.g. 70% and you need to go flying immediately). Another significant advantage is possibility of charging cells with higher currents than balancer may balance. Advantages of real balancers compared to voltage limiters are described in detail in „Not all balancers are balancers“ on www.mgm-compro.com.

It is possible to charge cells even without the service connector – in this case of course charger does not balance the cells. In this case, you also should check number of cells.

Built-in fan is turned on automatically if the temperature inside the charger exceeds a set limit. All states of the charger are indicated using color LED and a beeper. Charger can be connected to PC using USBCOM+ communication module and CC_03 cable (these are not included in AQCB – 4FC package) so that actual currents, voltage of cells, received charge both numerically and in graphs. All the data may be saved for later evaluation. Charger is feed from a car 12V battery or a means well 12 – 15V / 10A (source must be able to work with pulse load).

Charger also features shortcut protection and reversal of polarity protection.

Charger may work in 4 modes:

- a) standard Lipol – charging Lipol on 4.20 V (default setting)
- b) long life Lipol – charging Lipol on 4.15 V
- c) standard Li-Ion – charging Li-Ion on 4.10 V → it is possible to set number of cells and mode without balancing
- d) A123 system – charging Li-Ion on 3.60 V → it is possible to set number of cells and mode without balancing

Mode is easily set using jumper (Lipol / Li-Ion) and in addition to standard charging it also enables experimenting.

Kokam states significantly higher number of cycles (in thousands) for a shorter charging/discharging cycle to 80% in range of 4.15 V – 3.40 V when discharging with 1C currents. It can be supposed that increase of cycles can also apply to higher currents, even though thousands of cycles will not be a case here.

Instructions for use (charging simply and quickly):

On feeding wires of the charger solder connectors or crocodile clips depending on which supply you are using for charging. Red wire is +12V, black is minus. Make charging cables – connectors on one end will be the same as those on your battery pack, on the other end will be connectors G3.5 (Schulze or equivalent) for connection to the charger (it is also possible to order these cables – see accessories). If you wish to use the embedded balancer, which is strongly recommended, the battery must be furnished with service connectors „SCA_3“ up to „SCA_5“ - for pin orientation see page 4. You can use prolonged service cable. When you have battery pack with another service connector then MGM compro (SCA_3 up to SCA_5), you can make strapping cable very easy through use the set „SET_06“.

If you wish to charge Li-Ion cells first set the desired mode (Lipol cells are chosen default) – see next page. The chosen mode is indicated by blue LED during the whole time.

Charging battery packs without service connector (not recommended for Lipol cells):

- 1) turn the charger on by connecting it to supply (jumper „Lipol / Li-Ion“ is pulled out)
- 2) Set the required current on „current setup“ switch (if changed after the cells are connected the change is not applied!!!)
- 3) Set type and number of cells for Li-Ion or "A123 systems" (if not set earlier) – for detail see page 3
- 4) Connect the charging battery pack by cables into socket connector G3.5 in charger – this starts charging – charging process may be monitored on LEDs (yellow LED = current and charging phase)
- 5) Check number of cells detected by charger (signaled by green LED)
- 6) Charging is automatically finished when cells are charged (indicated by red LED and a beeper) – disconnect the cells
- 7) To charge another pack continue with step 2)

Charging battery packs with service connector:

- 1) turn the charger on by connecting it to supply (jumper „Lipol / Li-Ion“ is pulled out)
- 2) Set the required current on „current setup“ switch (if changed after the cells are connected the change is not applied!!!)
- 3) Connect the service connector to the charger
- 4) Connect the charging battery pack by cables into socket connectors G3.5 in charger – this starts charging – charging and balancing process may be monitored on LEDs (yellow LED = current and charging phase, green LED = balancer)
- 5) Check number of cells detected by charger (signaled by green LED)
- 6) Charging is automatically finished when cells are charged (indicated by red LED and a beeper) – disconnect the cells
- 7) To charge another pack continue with step 2)

Battery pack with power leads, MP JET connectors and service connector



AQCB – 4FC

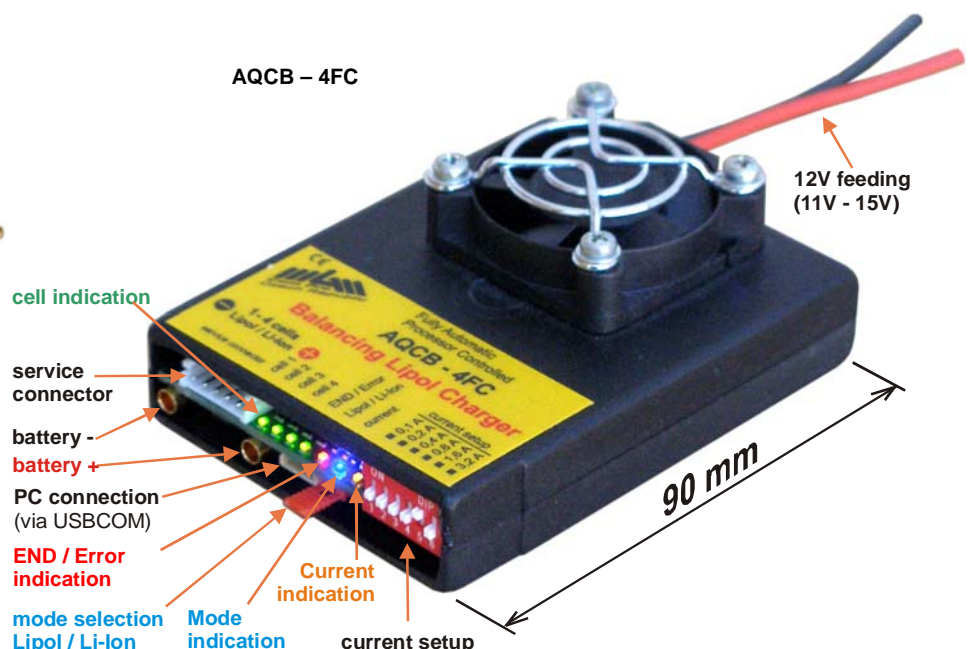

Charging with connected PC:

- 1) turn the charger on by connecting it to supply (jumper „Lipol / Li-Ion“ is pulled out)
- 2) Set the required current on „current setup“ switch
- 3) Connect the service connector to the charger (if you charge using service connector)
- 4) Connect AQCB to PC using CC_03 cable and USBCOM+ module and run „Charge Monitor“ application
- 5) Connect the charging battery pack by cables into socket connectors G3.5 in charger – this starts charging – on the connected PC you may monitor actual voltage of all cells, whole voltage, charging current and supplied charge – in numeric form and id graphs
- 6) Continue as in the above cases

Graph is drawn in real time. It may be maximized anytime, as well as zoomed in any chosen area with accuracy of units of mV. Also actual values of voltages of each cell, overall voltage of the battery, currents and supplied charge, input voltage is displayed under the graph.

For more details on controlling the application see “Charge Monitor control”

An example of intentionally unbalanced 3 cell pack of 1200 mA charged by 1.6 A is shown in the figures. It is obvious that the charger balances the cells in the first few minutes of the charging process and then the balanced cells are being charged together. This means that even if you finish charging early the cells will already be balanced in most cases.

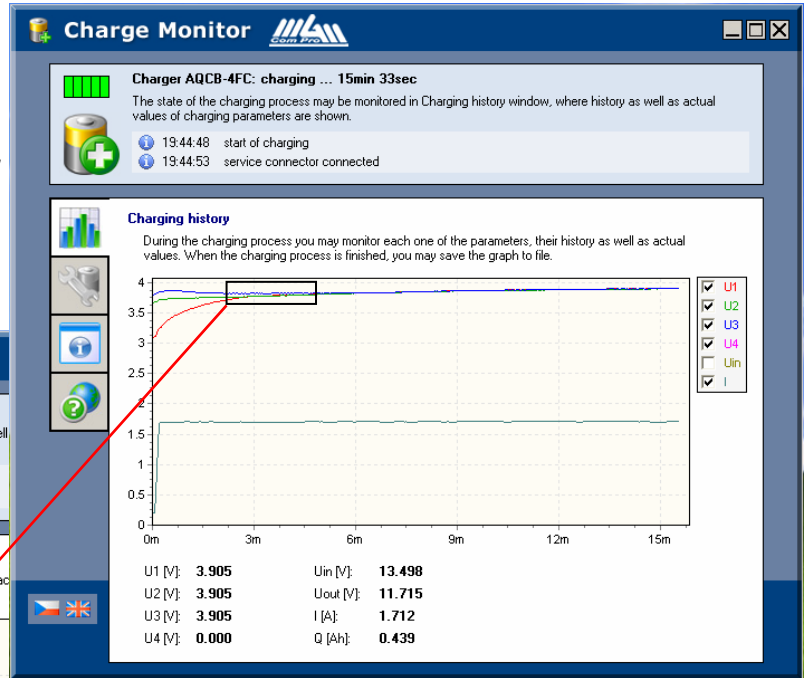
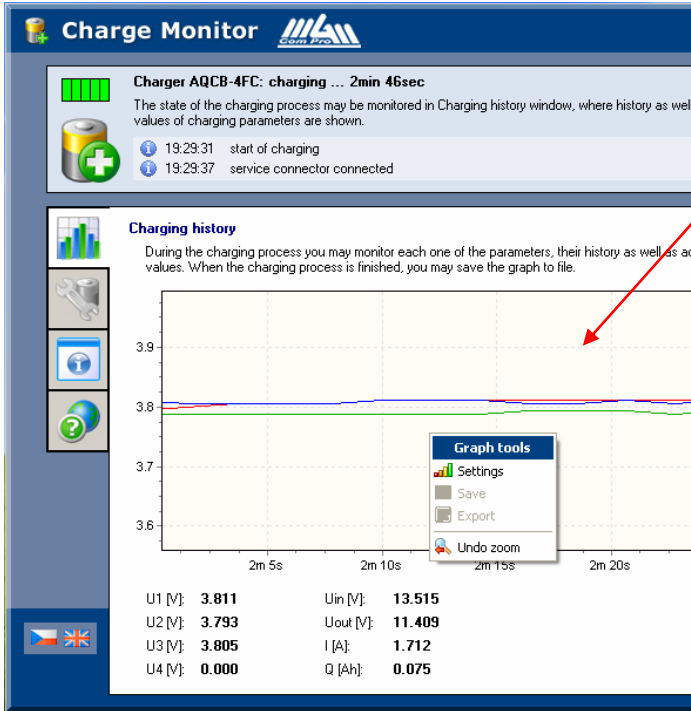

The end voltage of the charge was in this case set to 4.15 V / cell, that is mode: **b) long life Lipol**

Cells are balanced with tolerance of 6mV!!! it is possible to check with quality voltmeter on the cells

The charging process was automatically finished when current reached 114 mA.

Supplied charge 1.275 Ah some of the charge is “lost” due to balancing”.

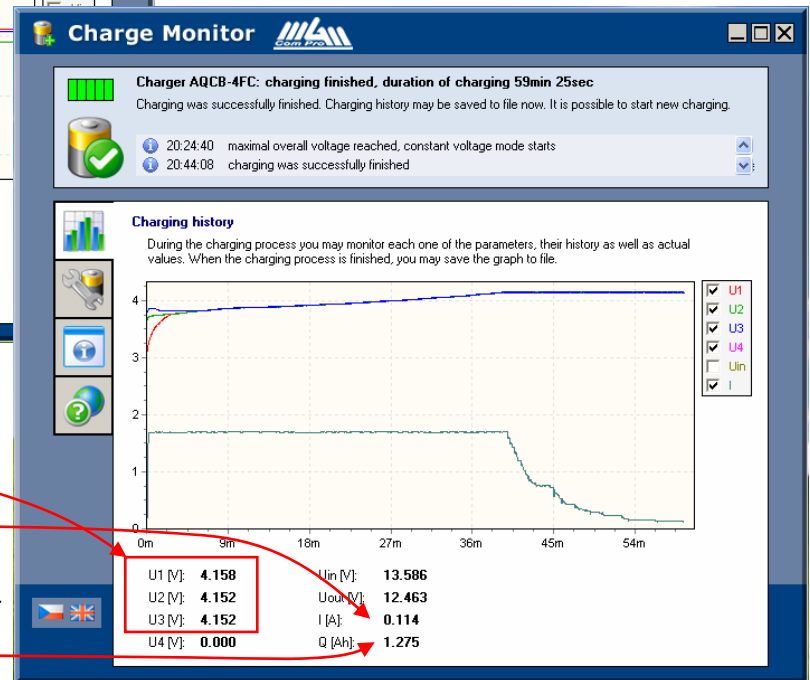

Connecting to PC:

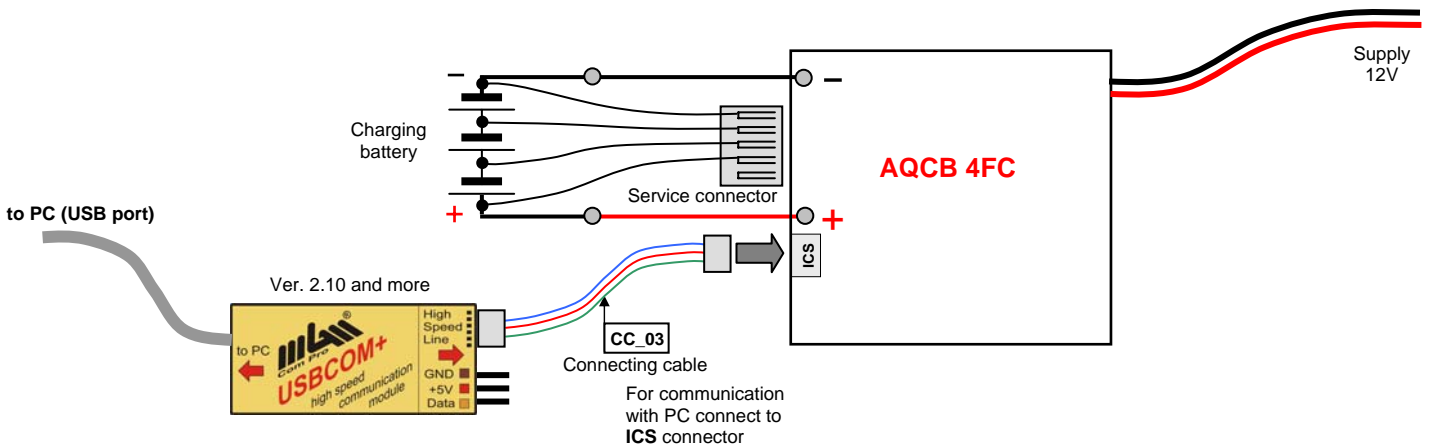

Settings and indications:

1. Mode setting (make only for change mode setting):

- 1) turn the charger on by connecting it to supply
- 2) plug in „Lipol/Li-Ion“ jumper
- 3) wait for beep and flash of **blue LED** with longer pauses
- 4) the required mode is set according after which beep and blue LED flash the jumper is pulled out (e.g. when you pull it out after third beep = mode is „Li-Ion 4.10V“). The set mode is saved in the memory until future change. Change of mode is possible make everytime, when is disconnect charging battery (step 2 – 4). When you have set requested mode it is possible to start charging.

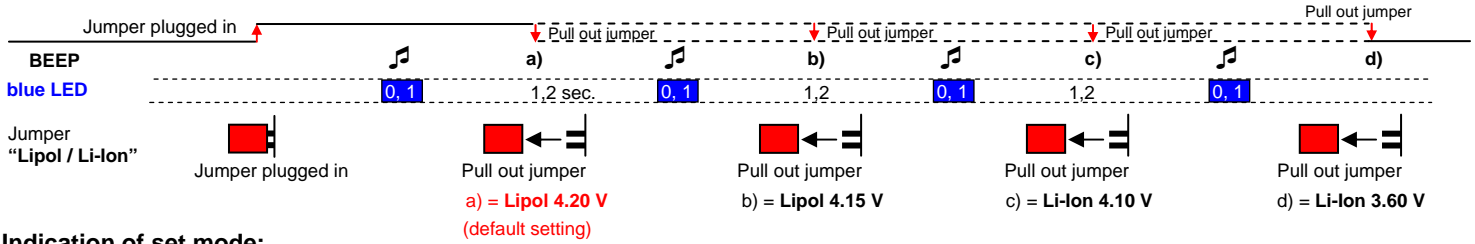

2. Indication of set mode:

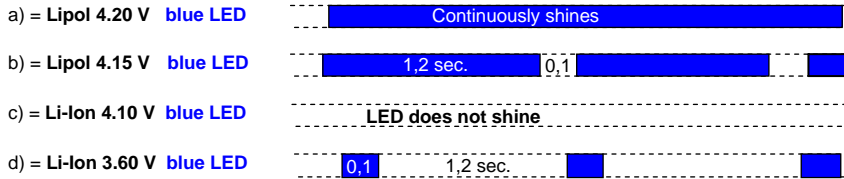

It is necessary to set also number of cells for modes **Li-Ion 4.10V c)** and **Li-Ion 3.60V d)** if charging without service cable.

- 5) When the coupler is taken out **blue LED** starts to flash in these modes. This state lasts for about 4 seconds.

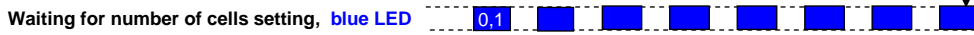

If in this time a coupler is inserted again, setting of number of cells starts by lighting up particular **green LEDs**. When correct number of cells is set take the coupler out. (same procedure as with mode setting).

3. How to set the charging current:

Desired current is set by the „current setup“ switch. Each switch corresponds to a current (0,1A / 0,2A / / 3,2A). Charging current given by addition of all currents in active positions. Active position of the switch is the upper one. The current is set before connecting the batteries to charger – later changes do not change the charging current.

When setting the charging current follow the recommendations of the Li-Ion or Lipol cells !

The smallest current is 0.1 A.

Biggest current is 5.A (if higher current is set it will be limited to 5.0A)

Example:

You wish to set the charging current at 3.5A:

(move the following switches to upper position $0.1 + 0.2 + 3.2 = 3.5A$)

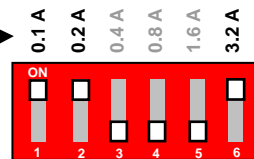

In the upper position the switch is active and the current is counted to the final charging current

4. Indication of the charging current magnitude:

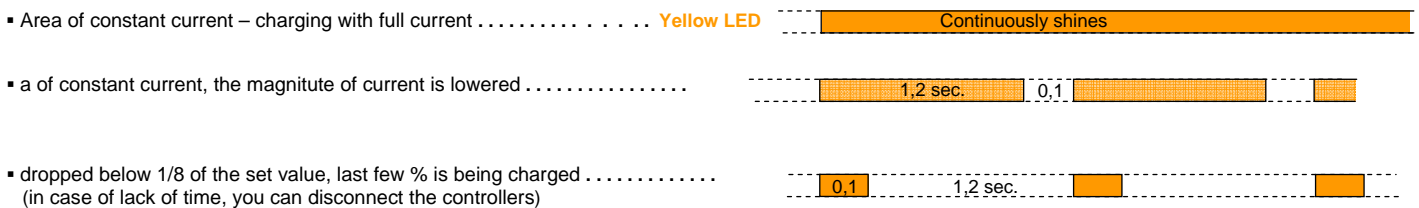

5. Start / finish of charging:

Charging starts when the battery pack is connected to the charger with power wires. It does not matter if the servicable is connected at first or after turning on the charger. Charging is finished either automatically when the cells are charged or at anytime manually by disconnecting the cells from the power wires.

6. Indication after connecting battery:

- after turning on (after connecting the batteries to balancer by service cable) number of connected cells is indicated by green LEDs for about 5 sec. and also acoustically with as many beeps as connected cells
- if in this time **green LED** of any cell is not lit, the voltage of this cell is < 3V (<2V in mode „d“), cell is missing or wire / service connector is damaged !!!! (**must be repaired**)

After 5 sec. LED are turned off and the balancing process starts (**only with service cable !**). The intensity of **green LED** indicates the difference in voltage of most charged cell. If the voltages of cells are the same, LEDs are lit with the lowest intensity. **These LEDs are turned of each 1,3 s for 0,1s to indicate that the process is running:**

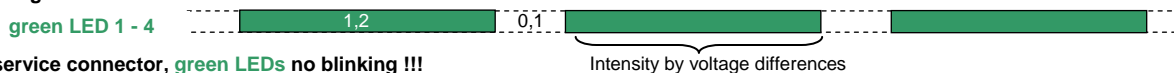

When is no used service connector, **green LEDs no blinking !!!**

Warning (warning of undercharged cells):

- voltage of the cell number 1 to 4 is lower then 3V !!! (<2V in mode „d“) (cell is undercharged, it is recommended to charge it with current of 0.1C)
- cell is not connected – service cable ripped off, fault connector, etc... (the corresponding **green LED** not lit up !!!)

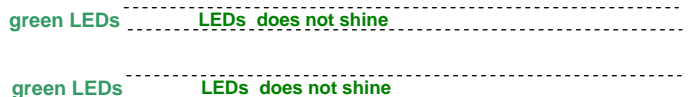

7. Indication of end of charging:

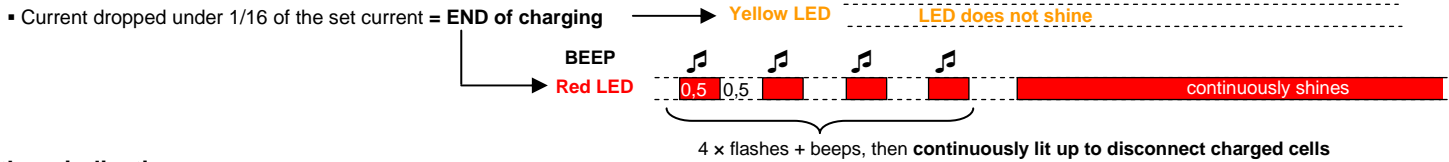

8. Others indication:

- Temperature of charger is over, charging current is going down - check fan, please !
- Input voltage is out of range !
- Defective service cable / connector or disconnect service cable STOP charging – it is need repair service cable
- Charger is under voltage and **waits for connection of battery** (other LED no shining, except **blue LED** „Lipol / Li-Ion“, which permanent displays setting mode)

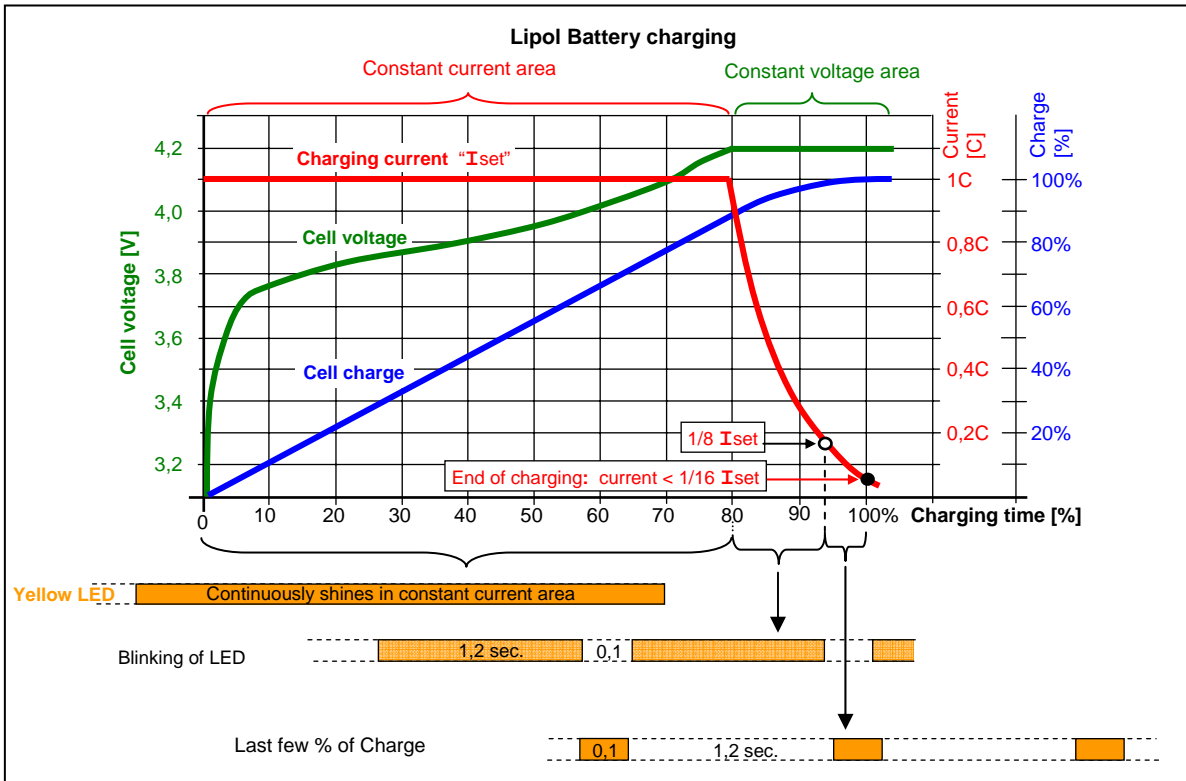
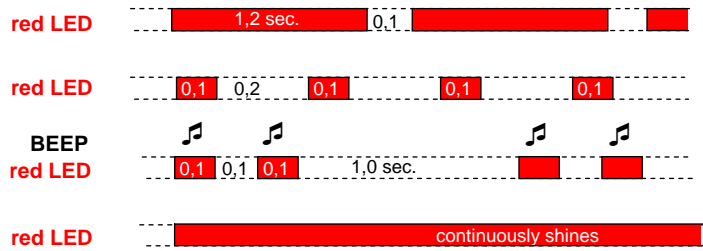

Technical data AQCB – 4FC:

Temperature of environment:	0°C up to 40°C
Input voltage of charger:	Battery 12V or power supply 13,8V (12 – 15V) / 10A *)
Number of charged cells:	1 – 4
Type of charged cells:	Lipol / Li-Ion / A123 systems
Minimal charging current:	0.1A
Maximal charging current:	5A
Current setting step:	100 mA
Charging method:	constant current / constant voltage, pulse operation
Balancing method:	real balancer, balancing during whole charging process
Balancing (service) connector:	JST, orientation of pins MGM compo
Accuracy of balancing (typically):	± 6 mV
End of charging:	automatically on 1/16 of set current / manually anytime
Balancing state indication:	intensity of light of LED
State and error state indication:	LED and/or BEEP
Connection to PC:	using CC_03 cable, USBCOM+ and program „Charge Monitor“
Weight:	120 g
Dimensions:	90x68x30 mm

*) Note : we don't recommend 12V power supply from PC
The appearance and operating data may be changed without prior notice.



ATTENTION: Possibility of charger damage or destroy cell (battery) or charges and loss of warranty may happen while:

- connecting different type of cell than is specified in technical data
- feeding from different source than specified (e.g. from 12V car socket when motor running)
- connecting battery with more cells then specified
- charging Li-xxx cells with installed inner protections
- shortcut of wires to the battery being charged
- shortcutting the wires of charger, taking the charged apart
- operating the charger in small sealed place or covering the charged while charging
- dropping into water or if water gets inside, metallic object inside

Orientation of pins of MGM Compro service connectors

It makes no sense to connect the service connector directly on the cell (if you have only one cell), thus make charging cables to which solder wires from service connector. Charging of the cell is much more accurate than without the service connector.

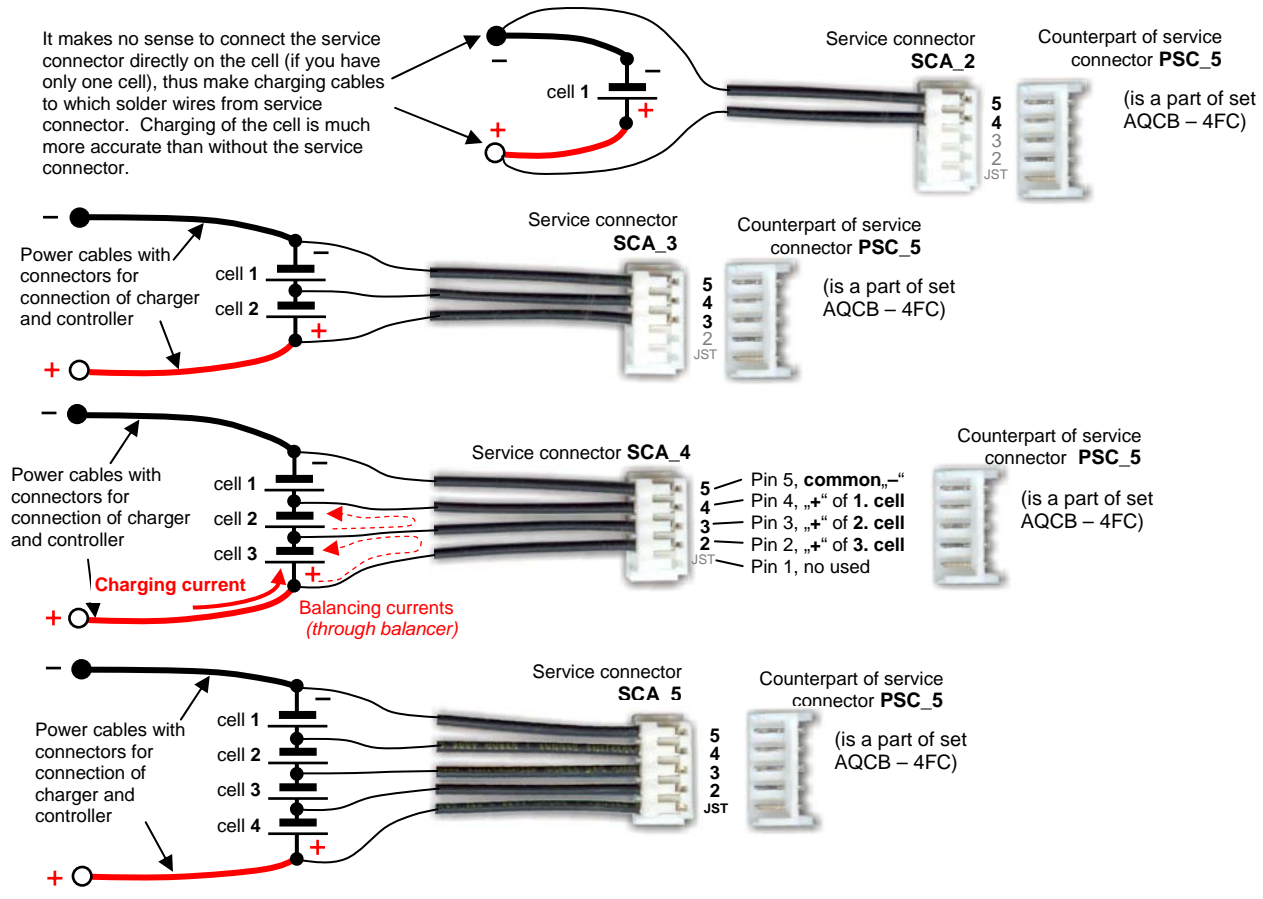

Charger Accessories:

Extension 5 pins service cable **PSCA_05**



Service connector **SCA_2, SCA_3, SCA_4** and **SCA_5** with wires 100mm or 300 mm (SCA_5 on picture)



Charging cables with connectors **MP JET 1.8, 2.5 or 3.5 mm**



SET_02: cable 1,5 mm² + connectors **G3.5** + shrinking tube



SET_06 – provide connect Li-xxx battery with any service connector to MGM compro devices (AQCB xx or BLCR xx)

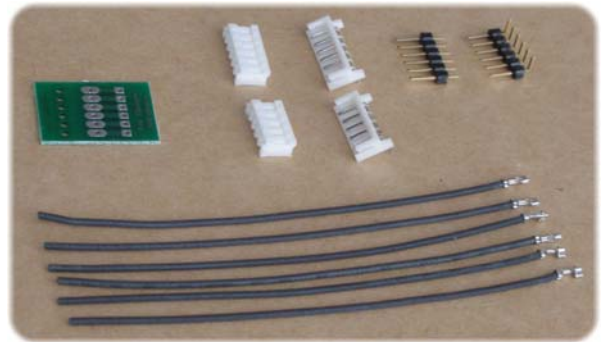

Communication module **USBCOM+**

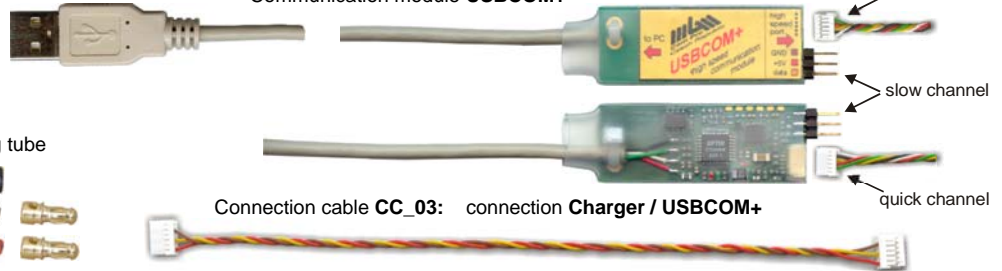

Safety Notice:

- do not use for charging of different types of batteries and different number of cells than specified
- do not leave the charger unattended when charging
- do not cover the charger (especially its fan) and the batteries while charging !
- do not expose to direct sunlight !
- protect from water !
- do not connect more battery packs at a time, each battery pack you charge must contain only the same types of cells
- do not charge damaged or fault cells or battery pack consisting of cells of different capacity, different types or different manufacturers !
- regarding **Li-xxx batteries** always make sure with your supplier what the charging voltage is, (whether 3.6, 4.1V or 4.2V) – **DO NOT INTERCHANGE !**
- **do not charge Li-xxx cells with installed protections - you may damage or destroy such cells !!!**
- **DO NOT REVERSE POLARITY** of cells !!!
- **please see on the cell / battery manual for correct value of charging current !!!**
- if the charger informs of any error states, please check the manual for errors and correct the error if possible
- **do not supply from different input voltage then specified !**
- **do not charge the batteries from lead (car) battery when the car motor is running** – voltage peaks may damage the charger !!!

