

Forward/Backward Programmable controllers TMM® xxxx – 3 car-boat for brushless sensorless motors (Ver. 2.30 and more)

Controllers TMM® xxxx – 3, car - boat are outstanding programmable controllers for brushless sensorless motors (BLCD motors). They are manufactured with the use of surface mounting from high-end components and are controlled by a very powerful processor. Controllers are ready for immediate use, no programming necessary, however programming is recommended. However, if you wish to set some parameters you may do so through a very simple process. These parameters are then saved permanently. The revolution regulation is extremely fine - 1024 steps all the way to the full throttle. The Mega BEC+ circuit (applies to versions with BEC) is also extremely powerful.

Thanks to the high-tech TMM® technology of MGM compo controllers feature number of outstanding properties which considerably eliminate the possibility of unwanted damage or destroy of motor, the batteries and the controller itself. Controllers also ensure the maximal efficiency with different kinds of motors.

Maximum attention is paid to development which is in continuous progress. To make our newest knowledge available to our customers the upgrade of SW is free (only shipping costs are charged).

The quality of products is under constant supervision in manufacture. Every controller goes through numerous tests. The final test of each controller is done under the controller's full load.

Protective and safety mechanisms of TMM® controllers:

Accumulators are protected in three ways. Firstly, due to the use of automatic current fuse (ACF) the current overload of accumulators (and their possible damage) even at crisis points can be avoided. Secondly, the used system of intelligent power reduce (IPR) always ensures through measurements of number of cells, voltage, currents, accumulator condition and calculations an optimal point of starting continuous reduction of motor performance (it is applied when accumulators become heavily discharged) so that accumulator cells do not get extremely discharged. This, not mentioning other advantages, reduces the possibility of reversal of poles of lower cells.

This system at the same time **enables retaining defined energy for BEC (perfect RPC)** in controllers that have BEC which is of great significance for flying models (a crash due to running out of energy for receiver and servos can be avoided) Thirdly, it is the automatic current reduce (ACR) due to which a drop in voltage for BEC under extremely big current load (for every given controller) while motor starts does not occur.

The controllers efficiently **mask interference and drop-outs** up to 1.5 sec. When long-lasting drop-outs or interference occur the controller slowly reduces motor revolutions. After the signal is resumed the controller continuously gets to the requested power. Without the proper signal from the transmitter (e.g. transmitter is turned off), the motor neither jerks nor runs but is at standstill.

Thermal fuse of the controller is set to 90°C when performance is reduced to ca 60% After switching on, the temperature above 70°C is monitored; if the temperature is higher the controller does not start. New start is possible only after the controller temperature falls. Take notice that the controller warms up not only due to losses on switching transistor but also due to loss on BEC.

Another features of TMM® car / boat controllers:

Braking lights is possible directly connect to all car / boat controllers (option). These lights illuminate when car is braking (applies also for an automatic brake in neutral). These lights are available in two modifications – with two ultra bright LEDs (BL_02A) or with four ultra bright LEDs (BL_04A).

It is possible forward / backward setup or one way setup.

Controllers for higher currents (60A and more) are manufactured in two designs. The first one is similar to that of aircraft controllers that is the controller is enclosed in shrinking sleeve with axial wires. The second design features additional ribbed heat sinks (radiators) on both sides of controller ("CUBE" version - HCS_01 option). "CUBE" version is produced without power cables. On the controller are connectors sockets for plugs G3.5 only. Wires to battery and motor are connected using G3.5 plug connectors in socket 3.5 mm vertically to the controller – this design is much more preferable in term better cooling. Connectors G3.5 or wires with G3.5 connectors (on the controller side) are available as option. **IT IS NO POSSIBLE SOLDER CABLES DIRECTLY TO CONTROLLER OUTLETS** (for CUBE version) – **it is need use G3.5 connectors !**

Operating data:

Temperature of the environment:	0°C to 40°C	Number of regulation steps:	1024 / full throttle
Motor controlling:	PWM 8 kHz	Max. rpm for 2 poles motor:	150 000 rpm
Control signal:	positive pulses 1,5 ± 0,5 ms, period 10 + 30 ms		
User set parameters:	see programming		
MEGA BEC+:	5V / max. 4,0 A (power losses 5W continuous, 10W / 10 sec., 15W / 5 sec., max. 20W, see graph "BEC load")		
Power supply:	from batteries only: NiCd, NiMH, Li-Ion, Li-Pol		
Switch:	all controllers is made with switch also – "s" version (safe connection)		
Suitable for motors:	Mega AC, Model Motors, MP JET, PJS, Überall model, Hacker, Kontronik, LRK, Plettenberg, etc.		
Water proof:	for 2 to 20 pole motors of classical conception (rotor inside) and also for outrunners (rotor is on the outer side). for better resistance for humidity or water is possible add water proof protective coating.		

TMM® car / boat	1812-3	2512-3	4412-3	6012-3	8012-3	12012-3	16012-3	16016-3	16024-3
Dimensions [mm]:	28×25×6	28×25×6	36×28×6	50×31×14	50×31×14	50×31×17	50×31×20	50×31×20	50×31×19
Dimensions (with external capacitor) [mm]:	28×25×6	28×25×6	51×28×6	62×31×14	62×31×14	65×31×17	65×31×20	65×31×20	80×31×19
No. of feeding NiCd/NiMH cells:	6 – 12	6 – 12	6 – 12	6 – 12	6 – 12	6 – 12	6 – 12	7 – 16	7 – 24
No. of feeding Li-Ion / Li-Pol cells:	2 – 4	2 – 4	2 – 4	2 – 4	2 – 4	2 – 4	2 – 4	3 – 5	3 – 8
Model:	M_BEC+	M_BEC+	M_BEC+	M_BEC+	M_BEC+	M_BEC+	M_BEC+	M_BEC+*)	OPTO
Max. current (for full throttle):	18 A	25 A	44 A	60 A	80 A	120 A	160 A	160 A	160 A
Max. current for 5 sec.:	23 A	30 A	55 A	70 A	100 A	150 A	200 A	200 A	200 A
On-state switch resistance at 25 °C:	2×3,7 mΩ	2×3,1 mΩ	2×1,2 mΩ	2×1,0 mΩ	2×0,67 mΩ	2×0,44 mΩ	2×0,33 mΩ	2×0,33 mΩ	2×0,35 mΩ
Power conductors length/cross-section:	1,0 mm ²	1,5 mm ²	2,5 mm ²	2,5 mm ²	2,5 mm ²	4 mm ²	4 mm ²	4 mm ²	4 mm ²
JR gold connector, cables:	0,25 mm ²	0,25 mm ²	0,25 mm ²	0,25 mm ²	0,25 mm ²	0,25 mm ²	0,25 mm ²	0,25 mm ²	0,15 mm ²
Weight incl. all conductors:	17 g	19 g	32 g	55 g	57 g	83 g	91 g	91 g	95 g
Weight without power conductors:	10 g	10 g	18 g	40 g	42 g	52 g	60 g	60 g	64 g

*) Note: BEC voltage is possible use up to 17V (4 Lipol or 12 Nixx cells). For higher voltages is need use external battery for receiver and servos supply. In this case is need remove central tap (red wire) from servoconnector.

The appearance and operating data may be changed without prior notice

Braking lights is possible connect to controllers directly (option)

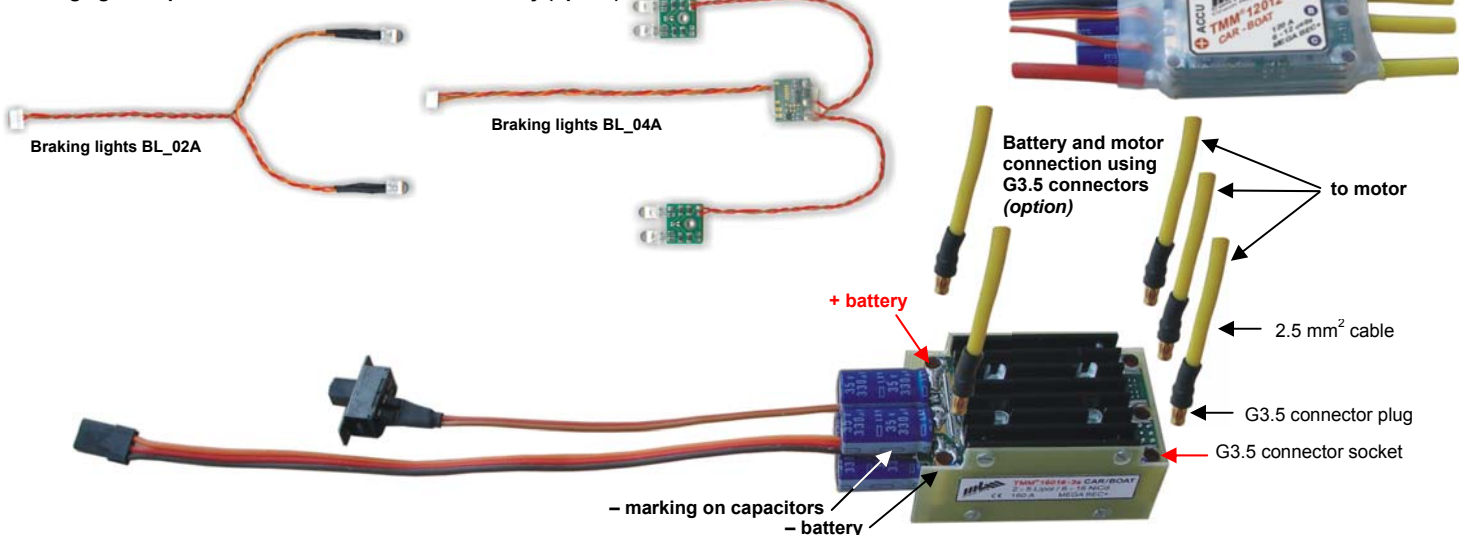

Design „cube“ with additional heat sinks, (option HCS_01) for 60A ESC and more

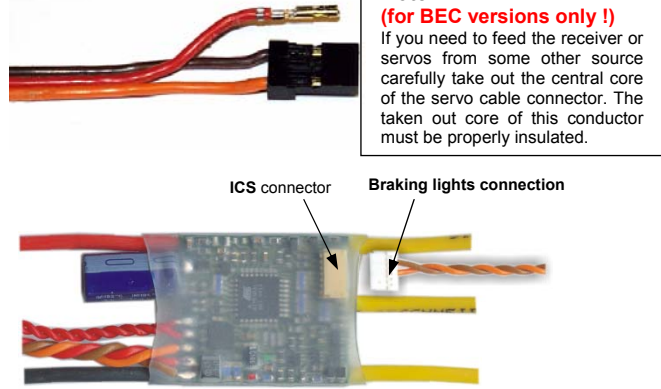
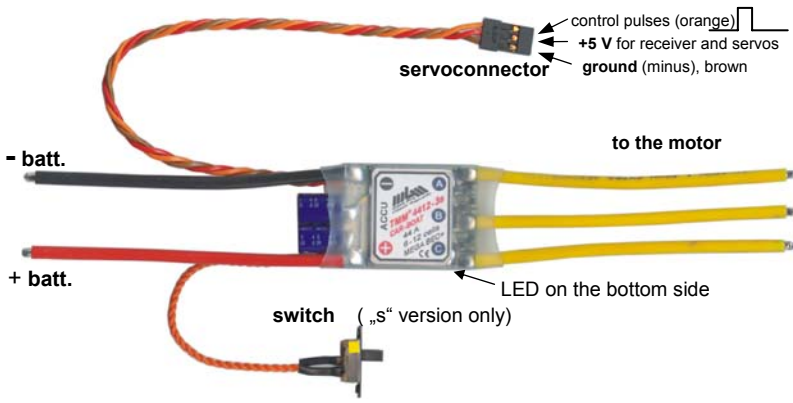

MEGA BEC: controllers up to 12 cells are equipped with BEC. The BEC can hold peak currents up to 4A and loss power loads which are significantly big but has its limits. It may not exceed 20W. It is possible to determine for example current which may be drawn from BEC under given load and voltage and also find out for how long from the graph. The power losses of the BEC warm the controller up. **It is necessary to remove the generated heat by airflow.** If the BEC is loaded with the power loss >5W pauses for cooling are necessary so that the average power loss is ≤ 5W. **REMEMBER that the controller is also heated by the power loss generated in the motor part!**

Power loss of 5V BEC: $(U_{BATT} - 5V) \times \text{current } I$

Example: (see graph) if voltage of batteries is 10.5V it is possible to draw current of 1.8A continuously for 10 sec. when the power loss of BEC is 10W. If the load would only take 5 sec. the power loss may be 15W and it is possible to draw current up to 2.7A.

Only version "MEGA BEC+" features long lasting shortcut protection!

When exceeding the maximal limits of current or power losses, BEC may be destroyed and the model may be uncontrollable!

Instructions for use:

- Opposite piece of the connector, which is on your accumulators, should be soldered to the leading-in conductors to the accumulator. Use only quality golden plated kinds. Recommend are MP JET 1.8mm, 2.5 or 3.5 mm according to the type of controller and current. It is also possible to use golden plated controllers Ø 4, resp. 2 mm or Schulze 3.5 mm (connectors are not interchangeable). MP JET connectors feature smaller transient resistance and also smaller dimensions. We recommend to put socket on the "-" wire (black wire) of the controller and the plug on the "+" wire (red wire).

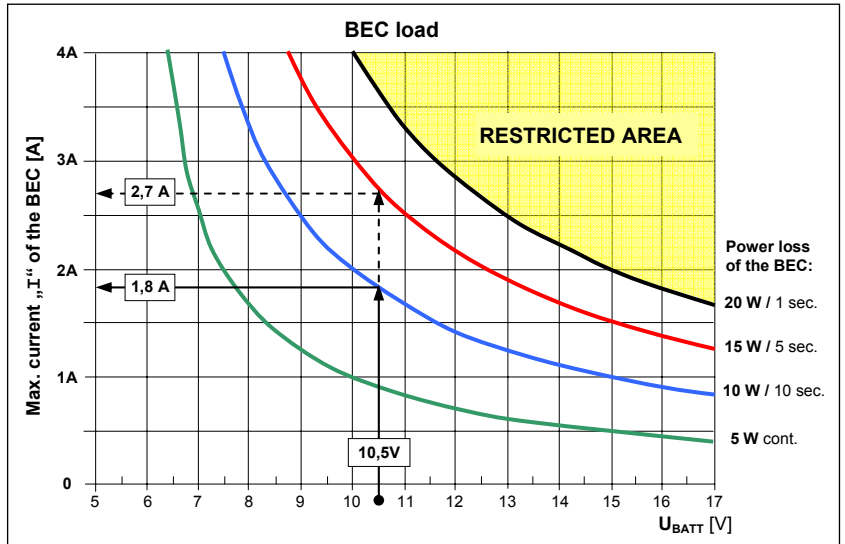

- Receiver and antenna should be placed as far as possible from the controller, the batteries and power leads. Antenna should be placed as far as possible from lead strings and cable to tail.
- NOTICE, reversal of poles on wires to the batteries will destroy the controller!** (This however, may not show immediately, but in some later starts or flights)
- The leads to the motor (yellow wires marked "A", "B", "C") should be soldered directly to the motor or it is also possible to use the connectors mentioned above. If you decide to use connectors, this time solder sockets to the controller leads!
Short cut of these wires together (when batteries are connected) or short cut of these wires to the feeding voltage results in damage or destroy of the controller!
- After the connectors are soldered it is necessary to isolate them, for example with heat shrinking sleeve!
- Use power conductors as short as possible – it is better for minimum weight and for minimum interference
- Connect the controller to throttle channel on the transmitter!
- If motor runs in an opposite direction than desired, swap any two motor phases or change the revolution direction in the program setting on PC (the PC change is available only for EXPERT controllers, not expert LT).
- It is necessary to cool the controller in operation with flowing air. Do not prevent the cooling air to get to the controller (e.g. by packing it in foam).**
- The controller informs about overload and overheating acoustically (motor beeping) and also through LED.
- It is not allowed to feed the controller from any other source (such as mains power supply) than specified types of accumulators!!!**
- The switch of the controller is connected in such way that even if it gets damaged the BEC will be still functioning.
- The controller is switched on by TURNING OFF the switch (applies to "s" version with switch) or by connecting batteries (applies to versions without switch).**
- Do not switch off or disconnect the controller from batteries when motor runs or when it is still turning – that may lead to damage or destroyed of controller!!!**

Error messages (the controller must be switched off to correct error, then switched on again):

- throttle stick was moved the opposite way then it is supposed to (the thrtholle stick was not in the min or max position at the beginning, and after beep it was moved to the max or min position to which the throttle was closer and not the other (correct way)
- low size of deflection of the throttle stick on the transmitter – you must shorten the size of deflection on transmitter
- overstep max. throttle position 0.5 and 2.5 ms – you must shorten the size of deflection
- switching on the controller with turned off transmitter
- starting an overheated controller
- overheating of controller during operation (only LED blinks, motor does not beep, the power is reduced to 60%)
- more or less cells than specified
- current overload (resumes operation after dropping throttle to zero, it is not necessary to switch the controller off in this case)
- signal drop out for long time

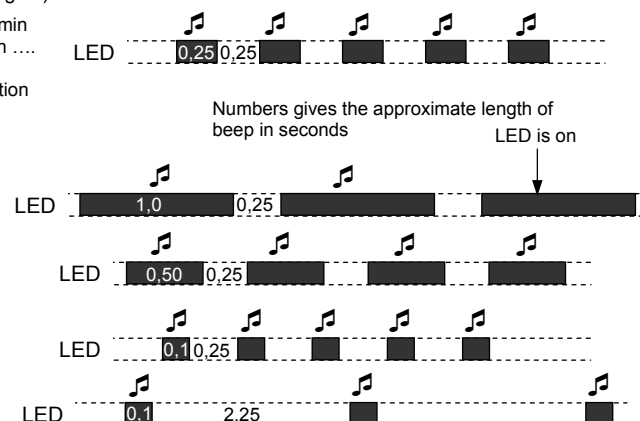

PROGRAMMING and operation:**! It is recommend to program the controller first !**

All programming is done thought transmitter and receiver with which the controller will run. After programming the data will be saved (until possible next programming) and the controller must be switched off. After switching it on again it is ready to use. If after switching on, the throttle stick is not in the **neutral** position the controller waits for it to get there (safety precaution) – if the throttle is in its **neutral** position you may take off immediately.

Description of parameters in the programming mode:

Parameter A – mode choice: „CAR” mode for cars, „BOAT” mode for boats, „**Automatic Tuning Settings**” for automatic controller optimization for a specific car). **In this version it is possible forward / backward setup or one way setup also.**

CAR mode forward / backward [A1]: If the car is at standstill, then by moving the throttle from neutral the car will go backward or forwards. If the car is moving then by moving the throttle backwards the car will brake. The brake is proportional, that means the further the throttle is from neutral the more intensive the brake is. The intensity of braking in the max throttle position may be set in parameter „B”. When braking the car will stop, and not start moving backwards until you move the throttle to neutral and then again backwards. Connected braking lights are turned on when braking.

BOAT mode forward / backward [A2]: in this mode the parameter „B” sets the speed in which the motor revolutions are reduced from maximum to the full stop. The direction of motor revolutions is reversed immediately upon moving the throttle the opposite way. The speed of slowing down and starting up is set in parameters „B” and „C”.

One way setup [A3, A4]: when you move throttle from neutral to back position, motor is only braking, no go to reverse of rotation.

Automatic Tuning Setting [A5]: this specialized mode serves for automatic controller performance optimization for your car. It is recommended to carry out during the first ride and after any change in the car (different motor, number of cells, type of cells...). After the „settings” ride which is done immediately after programming (no switch off controller !!!) into mode „Automatic Tuning Settings” the controller automatically goes back to earlier setting (CAR mode forward / backward or one way). This „settings” ride is done with all the earlier set parameters. During this ride, the car must go on full throttle at least for a while, the best is from the beginning – then the optimized setting is used even for this ride. „Automatic Tuning Setting” is not obligatory, the car will run, however, the parameter B, I and J will not be optimized before you go on the full throttle.

Parameter B – brake: CAR mode: enables to set 5 grades of intensity of proportional brake in the max. throttle position. Set according to your needs. If you need automatic brake in neutral position of throttle, set parameter „J”. For its optimal performance it is recommended to run **Automatic Tuning** setting, mode A5.

– **deceleration: BOAT mode:** enables to set the speed of deceleration in 5 grades, Set according to your needs.

Parameter C – acceleration: enables to set acceleration (acceleration speed of motor) in 5 steps. Set according to your needs.

Parameter D – timing: here you may choose (and experiment with) 5 different timings. The sixth possibility is automatic timing which is strongly recommended because it ensures optimal setting and maximal efficiency. While using the definite values of timing and higher timing you may rise the motor revolution or the twisting moment a bit but always at the expense of lowering the efficiency. If you wish to have higher revolutions it is better to use different motor or more cells because lower efficiency cannot be made up for. High value of timing may in unsuitable combination with some motors damage the controller!

Motor with high inductance: setup timing 5° or 10°, automatic timing cannot be optimal.

Parameter E – controller behavior when batteries are getting low: This parameters sets the controllers behavior at moment when the voltage on discharging curve of batteries gets to the point when controller starts to preserve the remaining energy for BEC. You may set continuous motor revolutions reduction or an immediate cut off (with the possibility of start when you lower the throttle to neutral). This depends on pilots customs. Both behaviors are quite alike regarding the residual energy.

Race mode: In race mode, the motor will be stopped when voltage of batteries drops below 5V, number of cells, their condition or current is not taken into consideration. After throttling down to neutral, the operation may be resumed. This mode is quite harsh on accumulators, particularly for those with more cells !!! Current fuse is disabled (that means it does not check maximal current !!!), the thermal fuse is set to 105°C. Warranty does not apply to a possible damage of controller when operating under this mode.

Parameter F – battery: choice of the battery type, NiCd, NiMH or Li-Ion, Li-Pol

Parameter G – range of the neutral zone: There exists a zone evaluated by the controller as „the neutral”. Here the motor is not fed, the brakes are or are not applied automatically, in case of an overcharge normal operating mode is resumed. This parameter may be changed according to your needs and requirements in the extent of ca 3 up to 20% of the full deflection of the throttle stick. The zone which is too narrow may be not evaluated reliably and the one which is too wide narrows the zone of step less control.

Parameter H – automatic correction of the neutral after each switching-on: If this parameter is not switched on, the position of the neutral is evaluated exactly according to the setup within the scope of basic programming. If this parameter is switched on, the correction to the throttle stick current neutral position is carried out after each controller switch-on. It can be used in such cases as are those when you easily (and unintentionally) move the trim thus changing the centre of the neutral. There is no need to carry out the basic programming again - upon the following switch-on of the controller the position of the neutral is set automatically. When switching the controller on, pay heed to the following - the transmitter must already be switched on and the throttle stick moved to the neutral position.

Parameter I – Freewheel: Operation without the switched on freewheel can be compared to a common car with an engaged gear. If you throttle down, the car gets braked to the value of a throttle stick new position. If you quickly move the throttle stick to the neutral position, the car finishes running due to inertia as if you were driving a common car without the engaged gear. If the freewheel is switched on, the motor gets disconnected (and does not brake) on each quicker dropping the throttle to a lower value (of course incl. the neutral); the motor gets disconnected until the car due to inertia slows down to the speed corresponding to the throttle stick new position. Then the motor gets fed again. Actually it is an electronic analogy of mechanical freewheels. The electronic analogy directly affects the motor and thus all driven axles. Operation with a switched on freewheel is suitable for roads and races, while with a switched off freewheel it is suitable for off-road (in the „car” mode only). For its optimal performance it is recommended to run **Automatic Tuning** setting, mode A5. (This parameter is set only in mode „CAR”)

Parameter J – automatic brake in neutral: Braking intensity in the neutral position is set in 7 steps - automatic brake for cars. It is similar to braking with the use of a motor in the real car. You can OFF this brake also. For its optimal performance it is recommended to run **Automatic Tuning** setting, mode A5. (This parameter is set only in mode „CAR”)

Note:

Set on your transmitter the biggest possible size of deflections, the control will be finer.

If you do not wish to use a full performance of the motor (in some direction), reduce the size of deflections (only after programming !!) on your transmitter; as a result, max. motor revolutions will be not achieved even if the throttle stick is moved into a full deflection position.

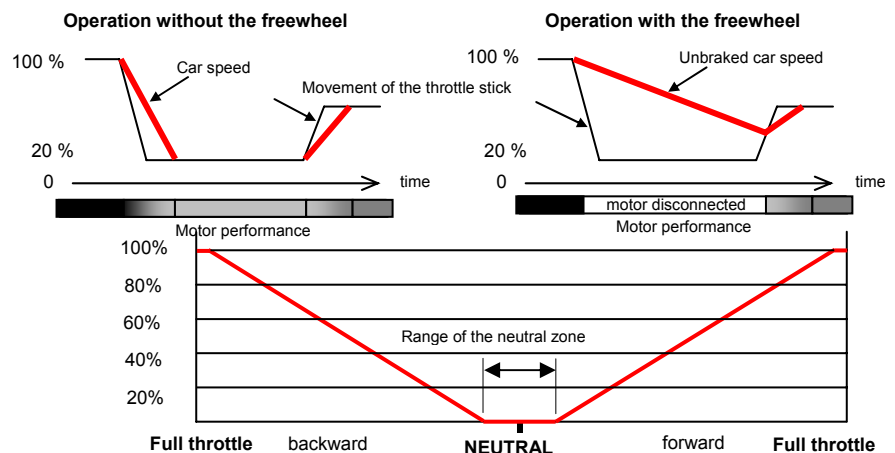
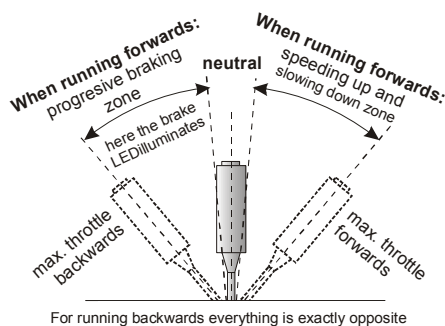
**Dependence of the current load peak on the speed of starting:**

If the current load peak loads the accumulators to such an extent that their voltage is about to drop under ca 4V, there automatically is lowered the speed of the onset of revolutions so that voltage does not drop under this limit.

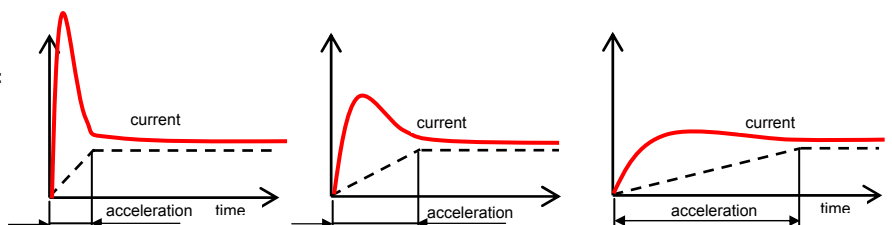

How to program the desired "value" in parameter you are setting (basic procedure in each parameter):

Move the throttle to the max throttle backwards position, LED will be blink 1x (once) and motor beeps 1x. Move throttle back to neutral position, LED will be blink 2x and motor beeps twice. Repeat this procedure (max throttle backwards position – neutral) as many times as is the number of parameter (according to the table) you wish to set. **For example:** for setting the **number 4** in parameter D (that is timing 15°) repeat the whole procedure (max throttle backwards position – neutral) **4x** (you certainly have to be in parameter D).

The programming of each parameter will be finished when you move the throttle from neutral position to the max throttle forward position—LED will be blink 3x and motor will beep 3x, then move the throttle back to neutral position, LED will be blink 2x and motor will beep 2x – the parameter is programmed to the value you have chosen and saved (**this sequence is marked as "ENTER"**). This also automatically gets you to next parameter. After the last programmed parameter the controller must to be always switched off first !

It is not obligatory to program all parameters – it is possible to switch the controller off after any parameter which is correctly finished by ENTER sequence. The following parameters will not be changed and all the preceding will be saved.

If you do not wish to change some parameter (you wish to preserve its last value) you directly set max. throttle forward position when programming it (no max throttle backwards position – neutral, but directly ENTER). The parameter value stay as it was before and the controller will get to the next parameter programming.

EASY return to default settings: start the controller with full throttle as if you were going to program. After 10 seconds the controller will beep 3 times. Do not move the throttle to break position but wait another 5 seconds for 4 beeps. After those, move the throttle to break position (in 3 seconds) and the default setting is resumed and BASIC mode is set. If the throttle is not moved to break position in the 3 seconds time, the setting will not change and controller waits for switch off.

The programming itself:**1) Turn the transmitter on with throttle stick in max. throttle forwards position !**

2) Turn on the controller. After 10seconds the controller will beep 3 x and LED will blink and stay turned on. Now you have 3 seconds to move the throttle to max throttle backwards position (full brake). If in this time limit you do not put the throttle in min position the programming process will end and the controller will be turned off. **Its next operation is possible after switching off and then turning on by switch (disconnecting and connecting of batteries).** If you put the throttle to full brake in this time limit, the motor will beep 1x and the LED will be blink 1x. Move throttle to neutral position, motor will beep 2x and the LED will be blink 2x. Now you are in the programming mode and may start to program parameters according to the procedure described above.

3) Parameter A – mode choice: CAR / BOAT / Automatic Tuning**I) You wish to set CAR mode forward / backward:**

Move the throttle to max throttle backwards position (full brake) position, LED will be blink 1x and the motor will be beep 1x. Move throttle back to neutral position, LED blink 2x and motor will beep 2x. This choice will be confirmed by moving the throttle from neutral to max throttle forwards position – LED will be blink 3x and motor will beep 3x. Then move back to neutral position and LED will be blink 2x and motor will beep 2x. It is set CAR mode and you may go to set next parameters.

II) You wish to set BOAT mode forward / backward:

Move the throttle to max throttle backwards position (full brake) position, LED will be blink 1x and the motor will be beep 1x. Move throttle back to neutral position, LED blink 2x and motor will beep 2x. **This sequence make two times (you must set number "2").** This choice will be confirmed by moving the throttle from neutral to max throttle forwards position – LED will be blink 3x and motor will beep 3x. Then move back to neutral position and LED will be blink 2x and motor will beep 2x. It is set BOAT mode and you may go to set next parameters.

III) You wish to set CAR mode one way:

Move the throttle to max throttle backwards position (full brake) position, LED will be blink 1x and the motor will be beep 1x. Move throttle back to neutral position, LED blink 2x and motor will beep 2x. **This sequence make three times (you must set number "3").** Confirm by ENTER.

IV) You wish to set BOAT mode one way:

Move the throttle to max throttle backwards position (full brake) position, LED will be blink 1x and the motor will be beep 1x. Move throttle back to neutral position, LED blink 2x and motor will beep 2x. **This sequence make four times (you must set number "4").** Confirm by ENTER.

V) Automatic Tuning mode:

Move the throttle to max throttle backwards position (full brake) position, LED will be blink 1x and the motor will be beep 1x. Move throttle back to neutral position, LED blink 2x and motor will beep 2x. **This sequence make five times (you must set number "5").** Confirm by ENTER. **No switch OFF controller!** After "ENTER" beeps you hear signaling of this mode: "beep – beep – beeeeeep". **Now, a ride under full throttle should be done.**

4) parameter B – brake / deceleration:

set according to the "How to program the desired value in parameter you are setting" (see above) set the desired value and move to next parameter

5) parameter C to J:

Set the desired value according to the table for each parameter. End and save each parameter by ENTER sequence which will also move to the next programmable parameter. Parameters which you do not wish to change may be skipped by directly performing ENTER sequence. After programming the last desired parameter **the programming is finish by performing ENTER.**

6) Turn of controller !

Parameter	Value of parameter →	0 (direct ENTER)	1	2	3	4	5	6	7	8
A	Mode choice	next parameter	„CAR“ mode ↔ forward / backward	„BOAT“ mode ↔ forward / backward	„CAR“ mode → one way	„BOAT“ mode → one way	Automatic Tuning	-	-	-
B	Brake (car) Deceleration (boat)	next parameter	Light	Medium	High	Hard	Very hard	-	-	-
C	Acceleration (from 0 to 100%)	next parameter	0,13 sec.	0,26 sec.	0,39 sec.	0,65 sec.	1,3 sec.	1,8 sec.	2,3 sec.	3,0 sec.
D	Timing	next parameter	automatic	5°	10°	15°	20°	25°	-	-
E	Behavior when battery voltage going down	next parameter	Slow reduce rpm	Motor cut off	RACE MODE	-	-	-	-	-
F	Battery type *)	next parameter	NiCd, NiMH	Li-Ion, Li-Pol 2 cells	Li-xxx 3 cells	Li-xxx 4 cells	Li-xxx 5 cells	Li-xxx 6 cells	Li-xxx 7 cells	Li-xxx 8 cells
G	Range of the neutral zone	next parameter	3%	6%	9%	12%	15%	18%	21%	24%
H	Automatic correction of the neutral after	next parameter	NO	YES	-	-	-	-	-	-
I	Freewheel	next parameter	NO	YES	-	-	-	-	-	-
J	Automatic brake in neutral	End of programming	NO	Very Light	Light	Medium 1	Medium 2	High	Hard	Very Hard

Notice: Default setting is **bold**.

*) maximal number of Lipol cells for a controller is given in technical specifications for each controller

PROGRAMMING TMM xxxx – 3, CAR - BOAT

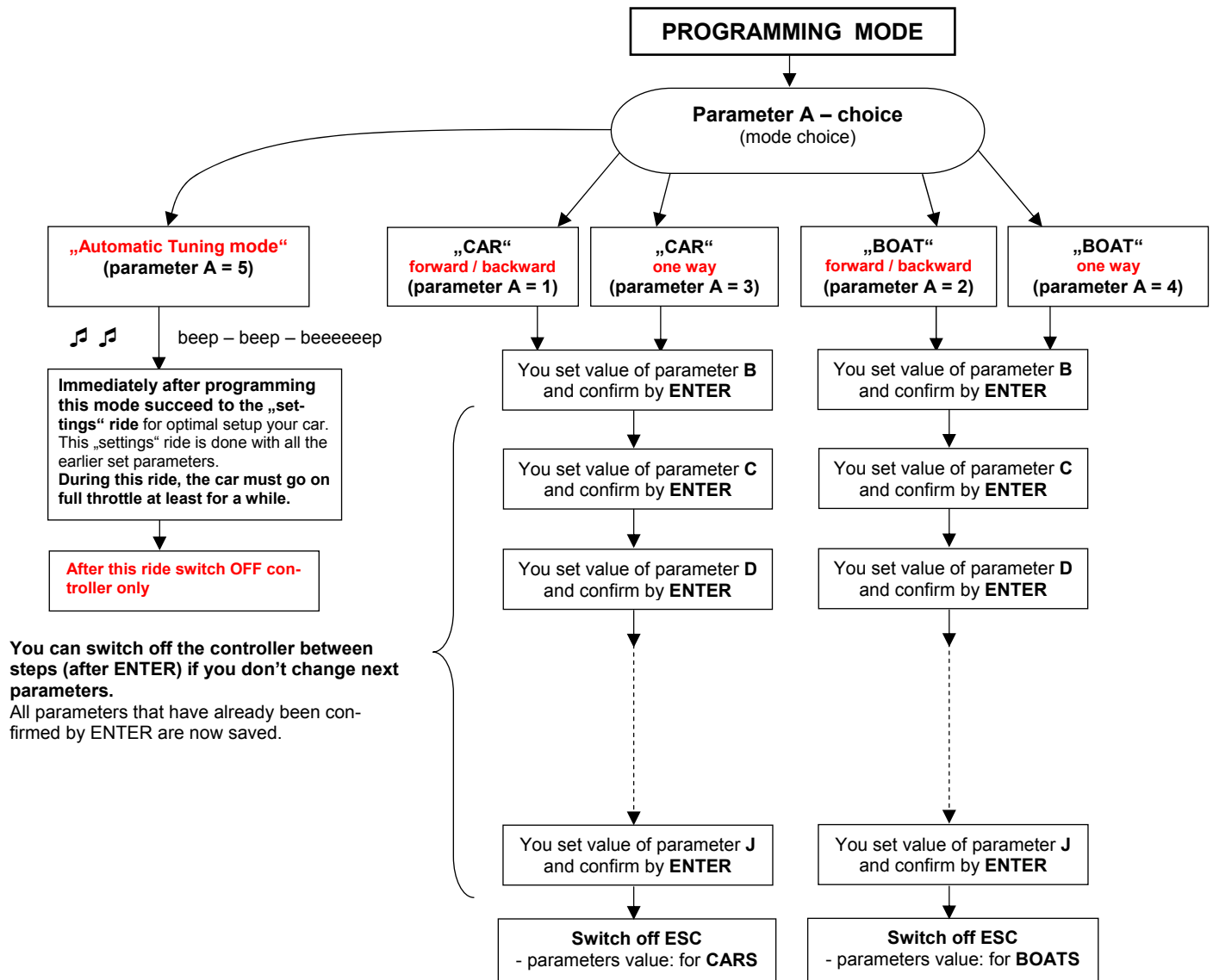

Legend (for the next page):

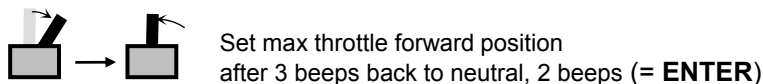
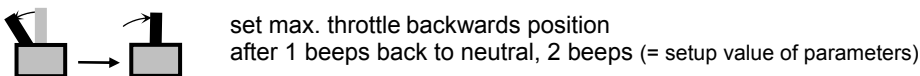
**SECURITY WARNING:**

Always disconnect the accumulators when not operating the model !!! Small current consumption occurs even when controller is switched off. Do not leave model with connected accumulators unattended ! Do not charge batteries when connected to the controller ! If the controller is connected to batteries do not stay in the reach of the propeller even when the controller is switched off ! Please notice that running car is very dangerous !

WARNING : You risk destroying the controller for:

- connecting more battery cells to the controller than the max. number specified in the technical data
- reversing connections to the accumulator
- shortcutting of wires to motor when batteries are connected
- changing motor and accumulator outlets
- overloading of the BEC with bigger currents or bigger power loss than is specified in technical data
- water in the controller (except for „hydro“ versions“)
- metal objects in the controller (screwdrivers, wires, etc.)
- disconnecting the controller from batteries or turning off the controller while motor is running (or still turning)

PROGRAMMING TMM xxxx – 3, CAR - BOAT

User parameters setup

Default parameters setup (factory settings)

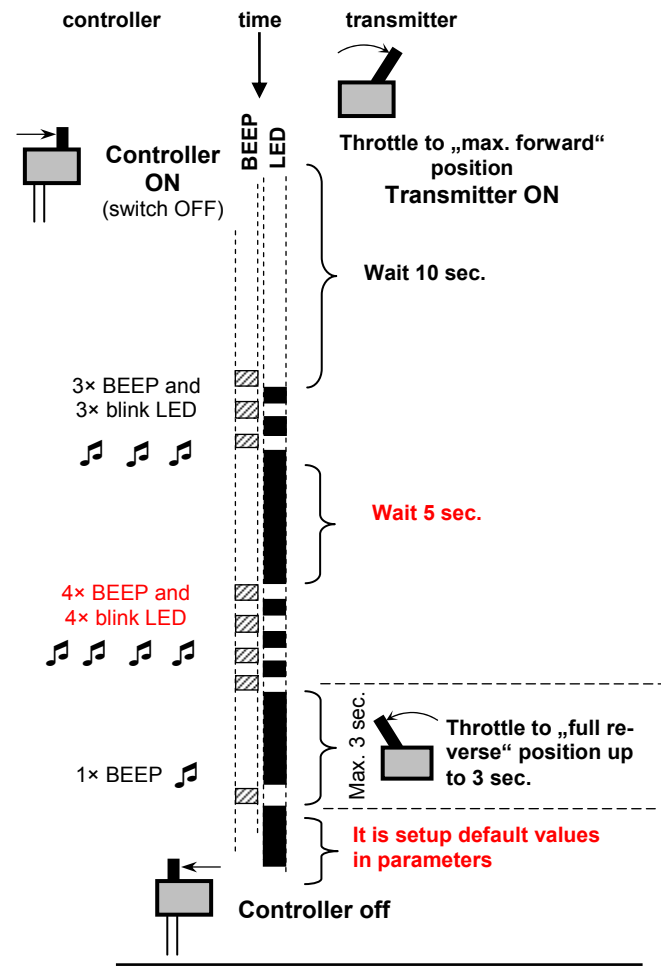
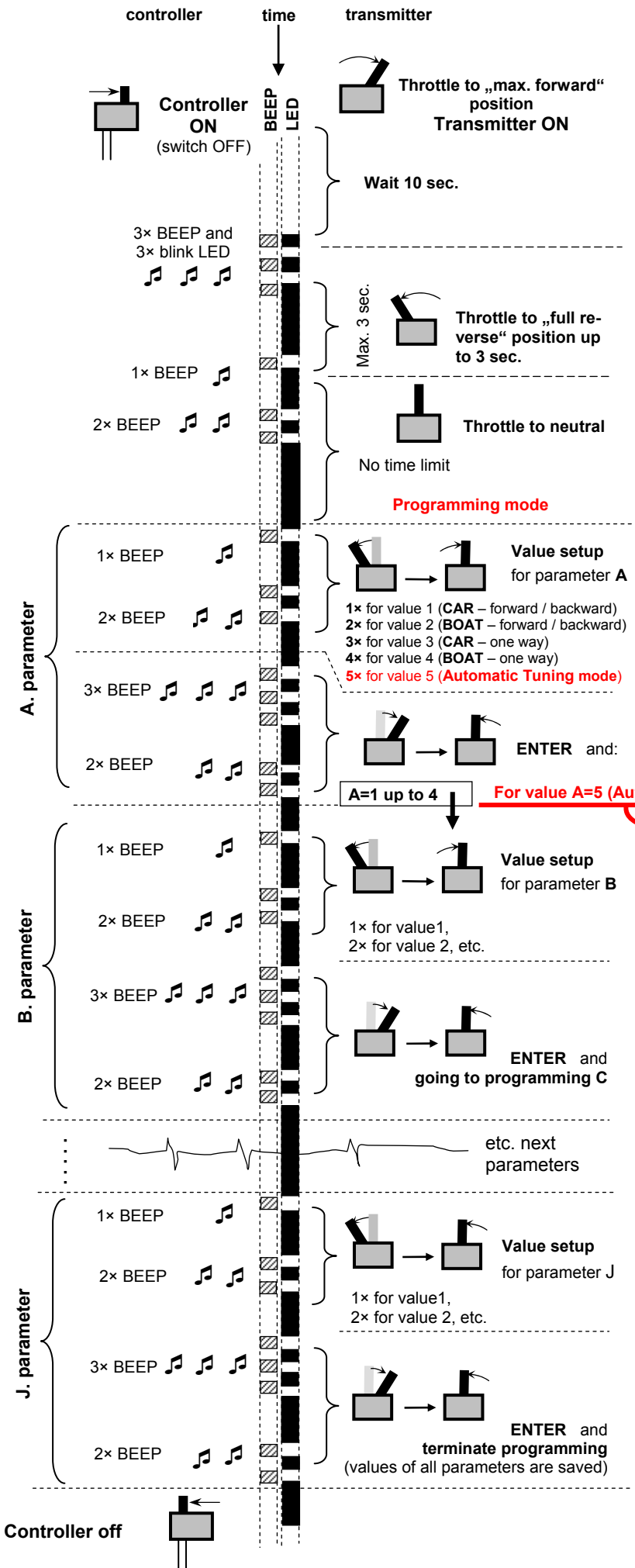

beep – beep – beeeeeeeep

Full steam ahead !

Immediately after programming this mode succeed to the „settings“ ride

